

Installation instructions

AUDI

A3 Sportback 2020 ►

A3 Saloon 2020 ►

**Removable towing bracket (ECE) for package
number 8Y0.092.150.***

Audi Genuine Accessories

Edition 02



Contents

1	General notes	1
2	Safety instructions for pyrotechnical, electrical and mechanical components of the restraint system	2
2.1	General safety instructions	2
2.2	Safety precautions when working on the SCR system	3
2.3	Storing, transporting and disposing of airbag, belt tensioner and battery disconnecter units (pyrotechnic components)	4
3	Notes on towing bracket — Fitting and operation	5
3.1	Notes on the towing vehicle	5
3.2	Notes on the towing bracket	5
3.2.1	Assembly	6
3.3	Operation	7
3.4	Bicycle carrier safety instructions	8
3.5	Sensitivity to side winds: safety instructions	8
3.6	Notes concerning ECE-R 55 mechanical coupling device guidelines	9
4	Overview of components	10
4.1	Overview of mechanical components Profsvar	10
4.2	Overview of mechanical components Westfalia	11
4.3	Overview of electrical system components	12
4.4	Additional required parts	12
5	Preparations	13
5.1	Disconnecting the battery	13
5.2	Remove the following components	13
6	Assembly overview and tightening torques	16
6.1	Assembly overview of towing bracket with cross member	16
6.2	Assembly overview of the electrics	18
7	Fitting the towing bracket	19
7.1	Sealing the threaded holes and body fold on the longitudinal member of the impact damper	19
7.2	Assembling the Profsvar towing bracket	20
7.3	Assembling the Westfalia towing bracket	21
7.4	Assembling the ball coupling for the Profsvar towing bracket	22
7.5	Disassembling the ball coupling for the Profsvar towing bracket	23
7.6	Assembling the ball coupling for the Westfalia towing bracket	23
7.7	Disassembling the ball coupling for the Westfalia towing bracket	23
7.8	Assembling the electric socket with side outlet for the Profsvar towing bracket	24
7.9	Assembling the electric socket with side outlet for Westfalia towing bracket	24
7.10	Routing the trailer socket wire to the trailer detector control unit -J345-	24



8	Electrical connection with preparation (1M5)	26
8.1	Installing the control unit bracket	26
8.2	Installing the trailer detector control unit J345	26
8.3	Pinning the retrofit wiring harness for the trailer socket to the connector for the trailer detector control unit -J345- and connecting the wiring harness to the trailer detector control unit -J345- ..	27
8.4	Plugging in the retrofit wiring harness for the onboard supply, CAN bus and brake light signal/ terminal 15	28
8.5	Establishing the earth connection	28
8.6	Inserting the fuses into the relay and fuse carrier	28
8.7	Connecting the CAN bus	29
9	Electrical connection without preparation (1D0)	30
9.1	Installing the control unit bracket	30
9.2	Installing the trailer detector control unit J345	30
9.3	Pinning the retrofit wiring harness for the trailer socket to the connector for the trailer detector control unit -J345- and connecting the wiring harness to the trailer detector control unit -J345- ..	31
9.4	Plugging in the retrofit wiring harness for the onboard supply, CAN bus and brake light signal/ terminal 15	32
9.5	Installing the onboard supply retrofit wiring harness	32
9.6	Removing the relay and fuse carrier	33
9.7	Establishing the power supply to terminal 30	33
9.8	Connecting the CAN bus/terminal 15 brake light signal	33
10	Concluding operations	36
10.1	Reassembling the vehicle	36
10.2	Connecting the battery	36
10.3	Adapting the trailer detector control unit -J345- activation process	36
10.4	Functional check on the socket	36
10.5	Reassembling the vehicle	37
10.6	Finishing the assembly work for the Profsva towing bracket	38
10.7	Adjusting the cooling system	38





1 General notes

Please read and take note of these WARNING, Caution and Note descriptions before carrying out maintenance or repair work.

 **WARNING**

Text with this symbol contains information concerning your safety and indicates potential accident and injury risks.

 **Caution**

Text with this symbol indicates the risk of damage to your vehicle.

 **Note**

Text with this symbol contains additional information.

 **Caution**

Towing mode places increased demands on the cooling system.

- ◆ *The cooling system ⇒ **Page 38** must be adapted to the vehicle operating conditions.*

Special tools are required for assembly. Improper installation can cause damage to the vehicle or the add-on parts.

 **WARNING**

For safety reasons, the towing bracket must only be fitted by skilled personnel – risk of accident!

AUDI AG shall not accept responsibility in the event of failure to comply with these installation instructions.



2 Safety instructions for pyrotechnical, electrical and mechanical components of the restraint system

2.1 General safety instructions

Pyrotechnical components comprise:

- ◆ Airbag units
- ◆ Belt tensioners
- ◆ Belt force limiters
- ◆ Battery disconnecting elements

General

- ◆ Testing, installation and maintenance tasks must only be carried out by trained personnel.
- ◆ There are no replacement intervals for airbag units.
- ◆ Do not check using circuit tester, voltmeter, or ohmmeter under any circumstances.
- ◆ Pyrotechnic components must only be checked when installed and using ⇒ vehicle diagnostic testers that have been approved by the manufacturer.
- ◆ When working on pyrotechnic components and the airbag control unit -J234-, the battery earth wire must be disconnected when the IGNITION is SWITCHED ON. The battery negative terminal must subsequently be covered.
- ◆ You must wait ten seconds after the battery -A- has been disconnected.
- ◆ The battery -A- must be connected when the IGNITION is SWITCHED ON. There must not be anybody inside the vehicle during this process. Exception: vehicles with battery -A- located inside the vehicle. Do not sit within the airbag and seat belt deployment range.
- ◆ Observe the appropriate steps after connecting the battery -A- .
- ◆ Before performing any work on pyrotechnic components in the restraint system, e.g. before disconnecting the electrical connector, the mechanic carrying out the task must discharge any static electricity. Electrostatic discharging can be performed by touching earthed metal parts, e.g. by briefly touching the door striker plate.
- ◆ Wash hands after touching ignited pyrotechnical components of the restraint system.
- ◆ Pyrotechnical components must neither be opened nor repaired. New parts must always be used (risk of injury).
- ◆ Pyrotechnic components that have fallen onto a hard surface or that show any sign of damage must not be installed.



- ◆ Pyrotechnic components must be installed immediately after they are removed from the transport container.
- ◆ If work is interrupted, the pyrotechnic component must be returned to the transport container.
- ◆ Pyrotechnic components must not be left unattended.
- ◆ When connecting the pyrotechnic components in the restraint system, only the person performing the work may be inside the vehicle.
- ◆ Pyrotechnic components must not be treated with grease, cleaning agents or similar products.
- ◆ If the fabric becomes contaminated with substances such as oil, grease, paint, colour or solvents, the airbag unit must be replaced.
- ◆ In addition, pyrotechnic components must not be exposed to temperatures above 100°C, even for short periods.

2.2 Safety precautions when working on the SCR system

WARNING

Risk of injury from the reducing agent.

The reducing agent can cause eye and skin irritation as well as respiratory problems and poisoning.

- Wear safety goggles.
- Wear protective gloves.
- Wear protective clothing.
- Ensure that there is a reliable supply of fresh air. Switch on an exhaust gas extraction system in enclosed spaces.

WARNING

Risk of damage from the reducing agent.

If the reducing agent comes into contact with the vehicle trims or bodywork, the reducing agent will eventually crystallise and damage the surface.

- Prevent the reducing agent from coming into contact with the vehicle trims or bodywork.
- In the event of contact with these surfaces, immediately remove the reducing agent using water and a cloth.



⚠ WARNING

When removing and installing components of the SCR system, note the following:

- ◆ *The reducing agent tank must be empty when working on the SCR system. The respective work description indicates at what point the reducing agent tank must be emptied. Draining the reducing agent tank; Disconnecting the SCR tank lines →Engine; Rep. gr. 26; SCR system; Draining the reducing agent tank*

Automatic back-siphonage of the reducing agent

- *When the ignition is switched off, the reducing agent is sucked back into the reducing agent tank from the supply line to the injector for reducing agent -N474-.*
- *Before working in this area, wait until back-siphonage is complete. This process can take up to ten minutes after the ignition is switched off.*
- *Also wait until back-siphonage is complete to disconnect the battery, i.e. wait ten minutes after the ignition has been switched off →Electrical system; Rep. gr. 27; Disconnecting and connecting the battery.*

2.3 Storing, transporting and disposing of airbag, belt tensioner and battery disconnecter units (pyrotechnic components)

- ◆ Storage is subject to the applicable national legislation.
- ◆ Transportation is subject to national and international laws governing packaging, naming, labelling and accompanying documentation.
- ◆ Pyrotechnic components that have not been ignited must be returned in the original packaging for appropriate recycling in line with the applicable national legislation! Contact your importer if you have any questions.
- ◆ Only pyrotechnic components that have been completely ignited may be disposed of as industrial waste.

⚠ WARNING

This does not apply for belt tensioners that operate according to the Wankel tensioner principle. Tensioners of this kind should be handled in the same way as pyrotechnic components that have not been ignited (e.g. airbags).

Background: For belt tensioners that operate according to the Wankel tensioner principle, it is not possible to check whether all ignition stages have completed using workshop tools.



3 Notes on towing bracket — Fitting and operation

3.1 Notes on the towing vehicle

Manufacturer: AUDI AG
 Model: A3 Sportback 2020 ►, A3 Saloon 2020 ►
 Offic. Type designation: GY

Maximum trailer weight or trailer drawbar load in kg, as specified by the manufacturer for the above-named vehicle model: ⇒ Vehicle registration certificate/Owner's Manual.

3.2 Notes on the towing bracket

Note

Check which towing bracket was delivered. Note the respective points of the different manufacturers Profsvar and Westfalia in these installation instructions.

Profsvar towing bracket

Technical data	
Profsvar no.:	TMB PS 147
Audi part No.:	8Y0.800.491
ECE No.:	55R-01 10663
D-value:	10.2 kN
Permitted trailer drawbar load:	80 kg

Westfalia towing bracket

Technical data	
Westfalia no.:	305 519
Audi part No.:	8Y0.803.881
ECE No.:	55R-02/00 4756 00
D-value:	10.2 kN
Permitted trailer drawbar load:	80 kg

WARNING

The drawbar load figures specified on the type plate of the towing bracket are test values only. Vehicle-specific figures are often lower than these values and can be found in the vehicle documents.

Please see your vehicle documents for your maximum trailer weight.



⚠ WARNING

Do not exceed the verified D-value and the permitted trailer drawbar load – risk of accident!

The towing bracket is intended for towing trailers fitted with a tow ball and for operating carriers suitable for mounting to the coupling ball.

Nationally applicable regulations must be adhered to in EU and non-EU countries.

Improper use is prohibited.

Use is only permitted under favourable road conditions and must be adapted to road conditions.

3.2.1 Assembly

⚠ WARNING

For safety reasons, the towing bracket must only be fitted by skilled personnel – risk of accident!

- ◆ ***If replacement parts are required, these must only be installed by skilled personnel and to undamaged genuine parts – risk of accident!***
- ◆ ***Installation must be in line with AUDI AG/Volkswagen AG guidelines – risk of accident!***
- ◆ ***Modification of the towing bracket is prohibited. This will invalidate the type approval – risk of accident and legal implications!***
- ◆ ***Use of the mounting points approved as standard by the vehicle manufacturer is mandatory – risk of accident!***

ⓘ Caution

Towing mode places increased demands on the cooling system.

- ◆ ***Please check with your Audi partner whether your vehicle has the required fan capacity for use at the full tow load.***
- ◆ ***You can also ask your Audi partner whether it is possible to retrofit your vehicle with a fan.***



3.3 Operation

WARNING

Vehicle handling is affected by the use of towing mode; increased driver awareness is required – risk of accident!

- ◆ **Read the notes in the “Towing mode” chapter of the ⇒ Owner’s Manual – risk of accident!**
- ◆ **If you are using trailer stabilisers, the coupling ball must be free from grease. Read and observe the notes in the relevant Owner’s Manuals – risk of accident!**

The diameter of the ball coupling must be checked at regular intervals.

- ◆ **For safety reasons, use of the towing bracket must be discontinued if the diameter reaches 49 mm at any point. If this situation occurs, contact a qualified workshop – risk of accident!**

For safety reasons, you are advised to remove the ball rod when not in use – risk of accident!

Do not tow using the eye – risk of breakage!

Caution

The ball coupling must always be kept clean. A cover must be used.

Note

- ◆ *The towing bracket including all assembly parts weighs approx. 17 kg.*
- ◆ *Please note that the kerb weight of your vehicle will increase by this amount once the towing bracket is fitted.*
- ◆ *Please make sure that you do not exceed the gross vehicle weight rating for your vehicle.*

Note

Use the towing bracket when towing.



3.4 Bicycle carrier safety instructions

WARNING

The bicycle carrier for the trailer towing coupling is only suitable for transporting bicycles – risk of accident!

- ◆ **The bicycle carrier for the towing bracket must only be used to transport bicycles with a total weight of max. 60 kg (132 lb). When carrying bicycles, the distance from the end of the vehicle to the last bicycle must not exceed 60 cm.**
- ◆ **The bicycle carrier for trailer towing coupling is not suitable for off-road use.**
- ◆ **Do not under any circumstances exceed the maximum load of the bicycle carrier for trailer towing coupling or the drawbar load of the trailer towing coupling.**
- ◆ **The combined weight of the towing bracket bicycle carrier and bicycles must not exceed the gross vehicle weight rating or the gross axle weight rating of the vehicle (⇒ owner's manual).**

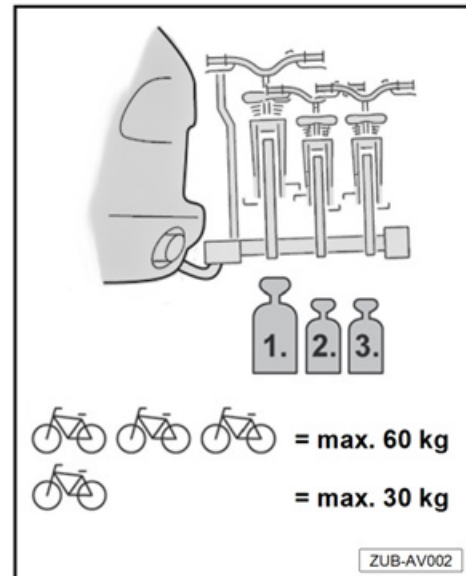

3.5 Sensitivity to side winds: safety instructions

WARNING

The load affects driving and braking behaviour and the vehicle's sensitivity to side winds. Adapt your driving style accordingly – risk of accident!

When driving in strong side winds, make sure that you take extra care:

- ◆ **When moving into and out of the slipstreams of lorries,**
- ◆ **When driving past hedgerows, trees, walls and buildings as well as any other wind barriers,**
- ◆ **When driving over bridges.**



3.6 Notes concerning ECE-R 55 mechanical coupling device guidelines

Make sure that clearance is provided in compliance with appendix 7, Figure 25a and 25b of the guideline ECE-R 55.

- 1 - Clearance
- 2 - Vertical plane through the end points of the vehicle's overall length
- 3 - Ground

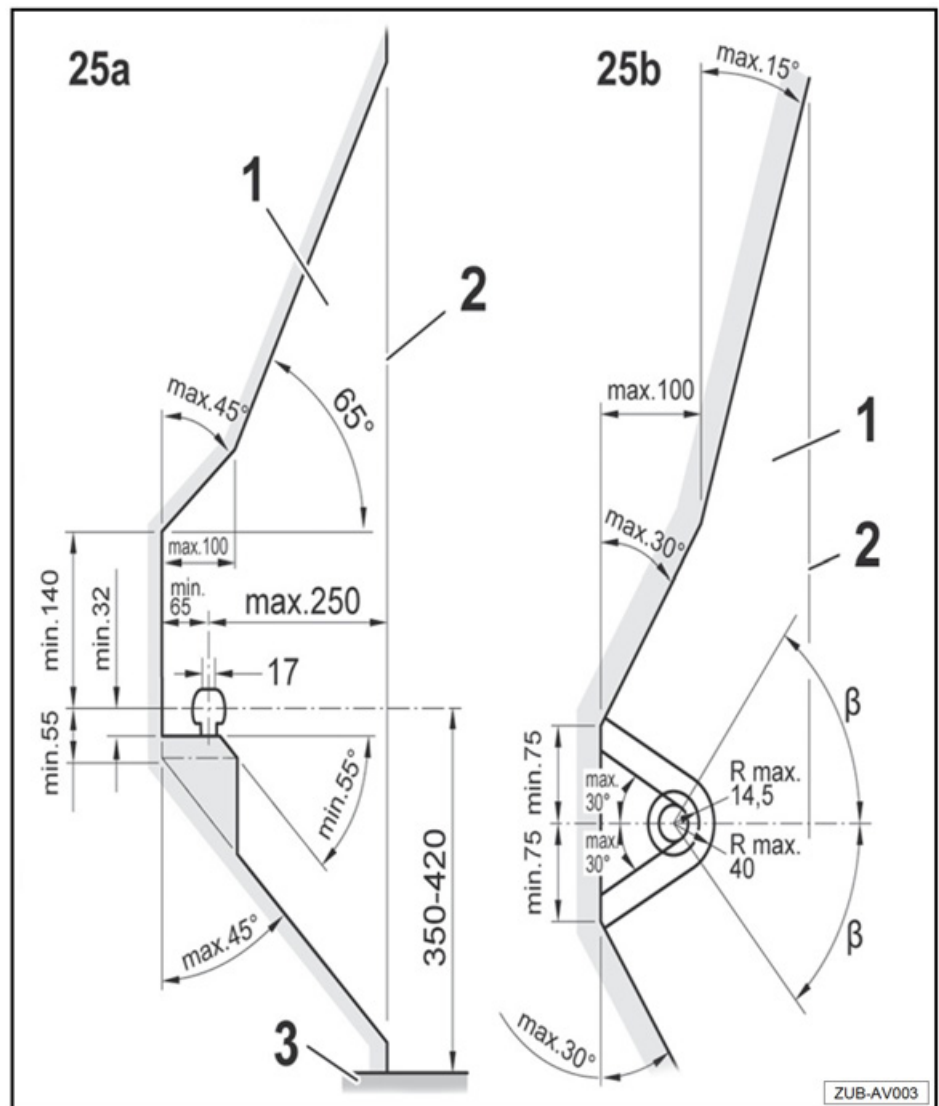

EN



4 Overview of components

4.1 Overview of mechanical components Profsvar

1 - Cross member with fixed/removable towing bracket

□ 1x

2 - Securing bolts for towing bracket

□ M10 x 40

□ 60 Nm + 90°

□ 4x

3 - Ball coupling; removable with key

□ 1x

4 - Ball coupling cover

□ 1x

5 - Protective cover

□ 1x

6 - Drawbar load sticker

□ 1x

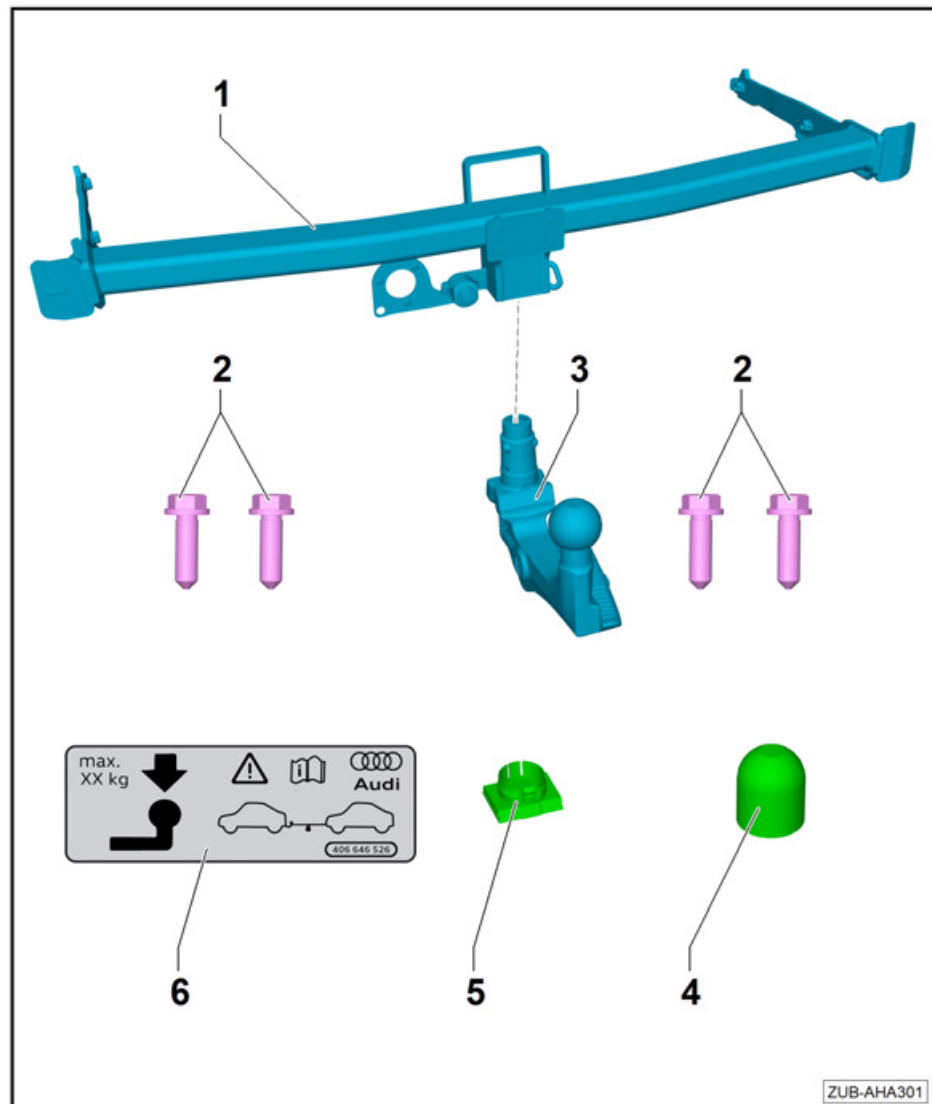

Type plate for the towing bracket

- The type plate is located on the bottom right next to the ball rod mount, as seen in the direction of travel.

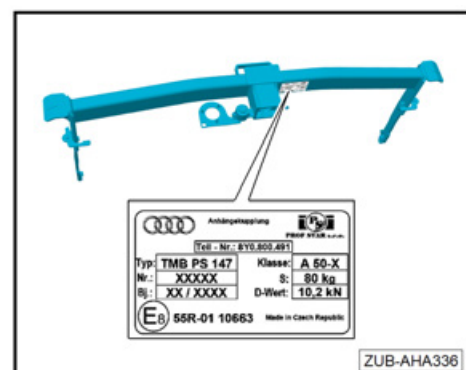

4.2 Overview of mechanical components Westfalia

1 - Cross member with fixed/removable towing bracket

☐ 1x

2 - Securing bolts for towing bracket

- ☐ M10 x 40
- ☐ 60 Nm + 90°
- ☐ 4x

3 - Ball coupling; removable with key

☐ 1x

4 - Ball coupling cover

☐ 1x

5 - Protective cover

☐ 1x

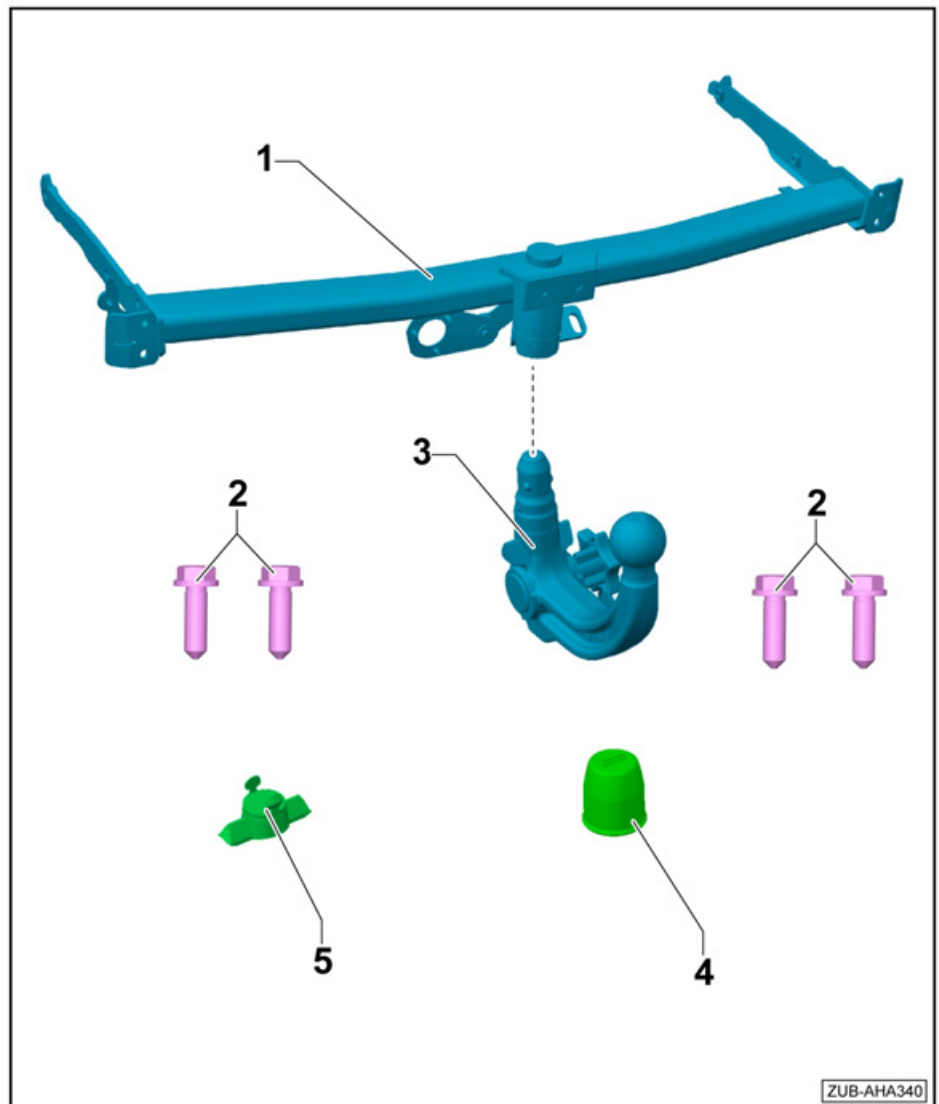

Type plate for the towing bracket

- The type plate is located on the bottom right next to the ball rod mount, as seen in the direction of travel.

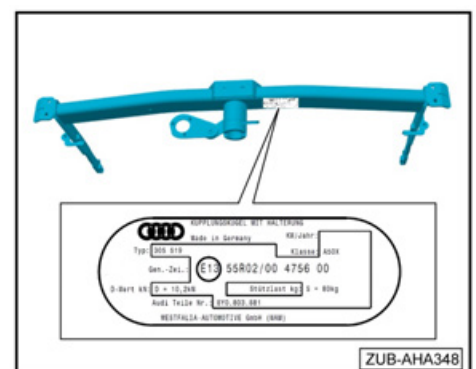



4.3 Overview of electrical system components

- 1 - Onboard supply retrofit wiring harness**
 - 1x
- 2 - PE bag**
 - 2x black three-pin connector housing
- 3 - Retrofit electrical socket wiring harness**
 - 1x
- 4 - 24-pin socket housing for connecting the trailer detector control unit -J345-**
 - 1x
- 5 - Activation document**
 - 1x
- 6 - Information sheet**
 - 1x
- 7 - Socket housing with 13-pin side outlet**
 - 1x
- 8 - Fitting trailer detector control unit -Hella-**
 - 1x
- 9 - Cable ties**
 - 160 mm
 - 10x
- 10 - Cable ties**
 - 300 mm
 - 2x
- 11 - Cable tie for edge clip**
 - 1x
- 12 - 15 A fuse**
 - 2x
- 13 - 25 A fuse**
 - 2x

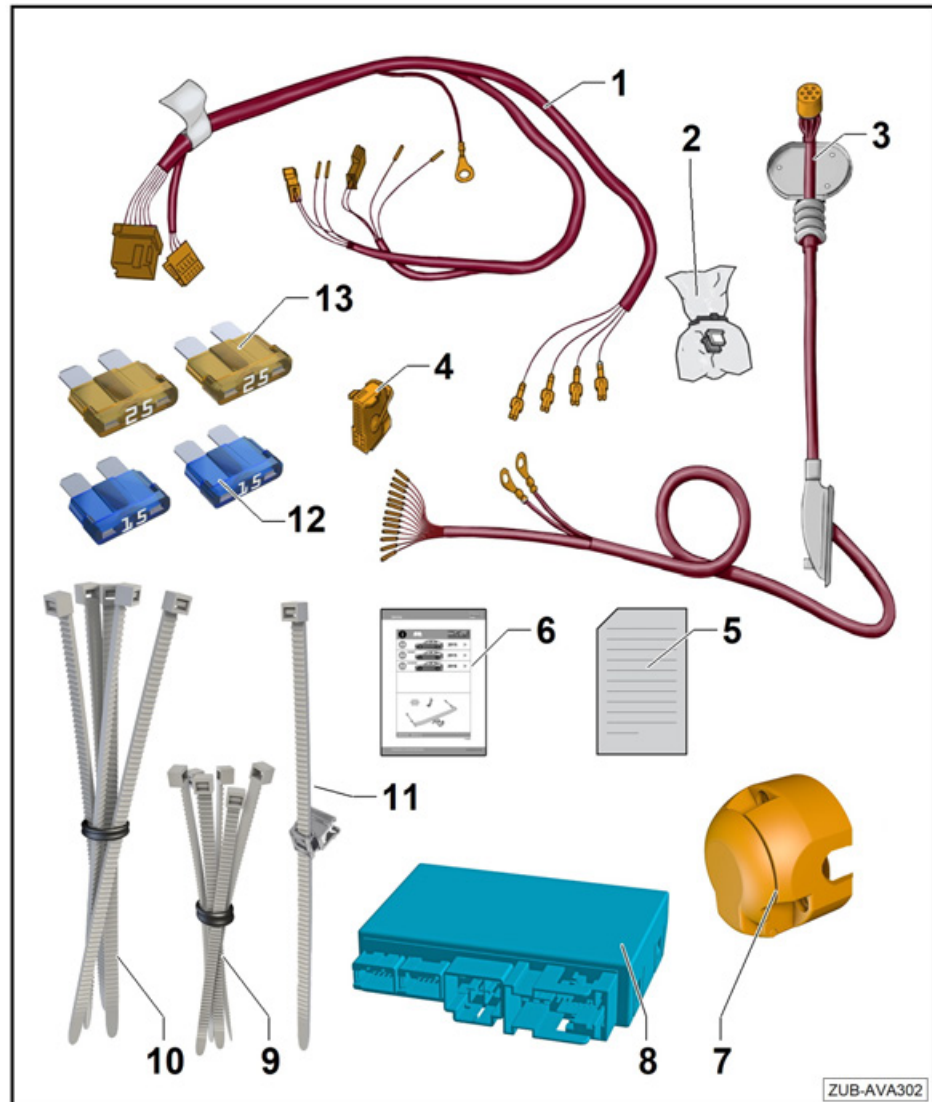

4.4 Additional required parts

Note

Any additional required parts for the various vehicle variants can be found in the ⇒ electronic parts catalogue ETKA



5 Preparations

5.1 Disconnecting the battery

Disconnect the battery ⇒ Electrical system; Rep. gr. 27; Battery; Disconnecting and connecting the battery



WARNING

- ◆ *Always make sure that the vehicle's electrical system is protected by disconnecting the battery before performing work on the electrical system.*
- ◆ *Only unscrew the battery negative terminal (-) of the battery.*
- ◆ *The battery positive terminal (+) of the battery must only be unscrewed once the battery has been removed from the vehicle.*

5.2 Remove the following components

Special tools and workshop equipment required

- ◆ Removal lever -80 - 200-

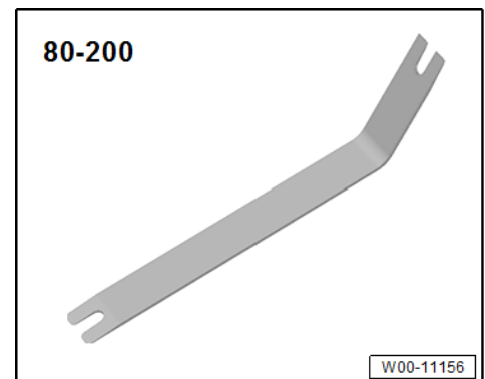

- ◆ Wedge -3409-

Assembly overview of bench seat ⇒ General body repairs, interior; Rep. gr. 72; Rear seat; Assembly overview — bench seat/individual seats

Remove the bench seat ⇒ General body repairs, interior; Rep. gr. 72; Rear seats; Installing and removing the bench seat/individual seats

Remove the rear seat backrest ⇒ General body repairs, interior; Rep. gr. 72; Rear seats; Installing and removing the rear seat backrest

Remove the luggage compartment floor mat ⇒ General body repairs, Interior; Rep. gr. 70; Luggage compartment trims; Removing and installing the luggage compartment floor

Remove the rear lid lock trim ⇒ General body repairs, interior; Rep. gr. 70; Luggage compartment trim; Removing and installing the rear lid lock trim

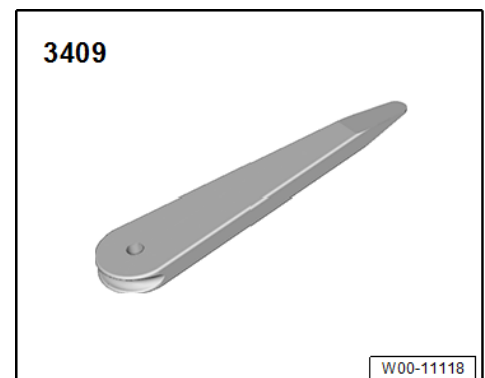



Remove the rear shelf ⇒ General body repairs, interior; Rep. gr. 70; Interior trims; Removing and installing the rear shelf

Assembly overview of luggage compartment side trim ⇒ General body repairs, interior; Rep. gr. 70; Luggage compartment trims; Assembly overview of luggage compartment side trim

Remove the left and right-hand luggage compartment lights ⇒ Electrical system; Rep. gr. 96; Lights; Removing and installing the left and right luggage compartment lights

Remove the fastening rings ⇒ General body repairs, Interior; Rep. gr. 70; Luggage compartment trims; Removing and installing the fastening rings

Remove the left-hand support for luggage compartment floor ⇒ General body repairs, interior; Rep. gr. 70; Luggage compartment trims; Removing and installing the support for the luggage compartment floor

Remove the left-hand luggage compartment side trim ⇒ General body repairs, interior; Rep. gr. 70; Luggage compartment trims; Removing and installing the luggage compartment side trim

Remove the right-hand luggage compartment side trim ⇒ General body repairs, interior; Rep. gr. 70; Luggage compartment trims; Removing and installing the right-hand luggage compartment side trim

Remove rear bumper cover ⇒ General body repairs, exterior; Rep. gr. 63; Rear bumper; Removing and installing the bumper

Remove the impact bar ⇒ General body repairs, exterior; Rep. gr. 63; Rear bumper; Removing and installing the impact bar

Remove the dash panel cover ⇒ General body repairs, interior; Rep. gr. 70; Interior trims; Removing and installing the dash panel cover on the driver side

Remove the gap cover on the A-pillar ⇒ General body repairs, interior; Rep. gr. 70; Interior trims; Removing and installing the gap cover on the A-pillar

Remove the bonnet actuating lever ⇒ General body repairs, interior; Rep. gr. 70; Interior trims; Removing and installing the bonnet actuating lever

Remove the lower left-hand section of the A-pillar trim ⇒ General body repairs, interior; Rep. gr. 70; Interior trim; Removing and installing the A-pillar trim

Remove the front left-hand sill panel trim ⇒ General body repairs, interior; Rep. gr. 70; Interior trims; Removing and installing the sill panel trim

Remove the upper left-hand section of the B-pillar trim ⇒ General body repairs, interior; Rep. gr. 70; Interior trim; Removing and installing the B-pillar trim



Remove the bottom left-hand section of the B-pillar trim ⇒ General body repairs, interior; Rep. gr. 70; Interior trim; Removing and installing the B-pillar trim

Remove the rear left-hand sill panel trim ⇒ General body repairs, interior; Rep. gr. 70; Interior trims; Removing and installing the sill panel trim

Depending on the equipment, the following items must also be removed:

Remove the rear right-hand wheel housing liner ⇒ General body repairs, exterior; Rep. gr. 66; Wheel housing liner; Removing the rear wheel housing liner

 **WARNING**

Applies only to vehicles with SCR system without activated charcoal filter (PR no.: 1E9)

Disconnect the SCR tank lines, see ⇒ Engine; Rep. gr. 26; SCR system; Removing and installing the reducing agent tank



6 Assembly overview and tightening torques

Assembly overview of towing bracket with cross member
⇒ “Assembly overview of towing bracket with cross member” on page 16

Assembly overview of the electrics ⇒ “Assembly overview of the electrics” on page 18

6.1 Assembly overview of towing bracket with cross member

Applies to Profsvar towing bracket

1 - Securing bolts

⇒ Page 20

- Replace after removal
- M10 x 40
- 60 Nm + 90°

2 - Trailer towing coupling with cross member

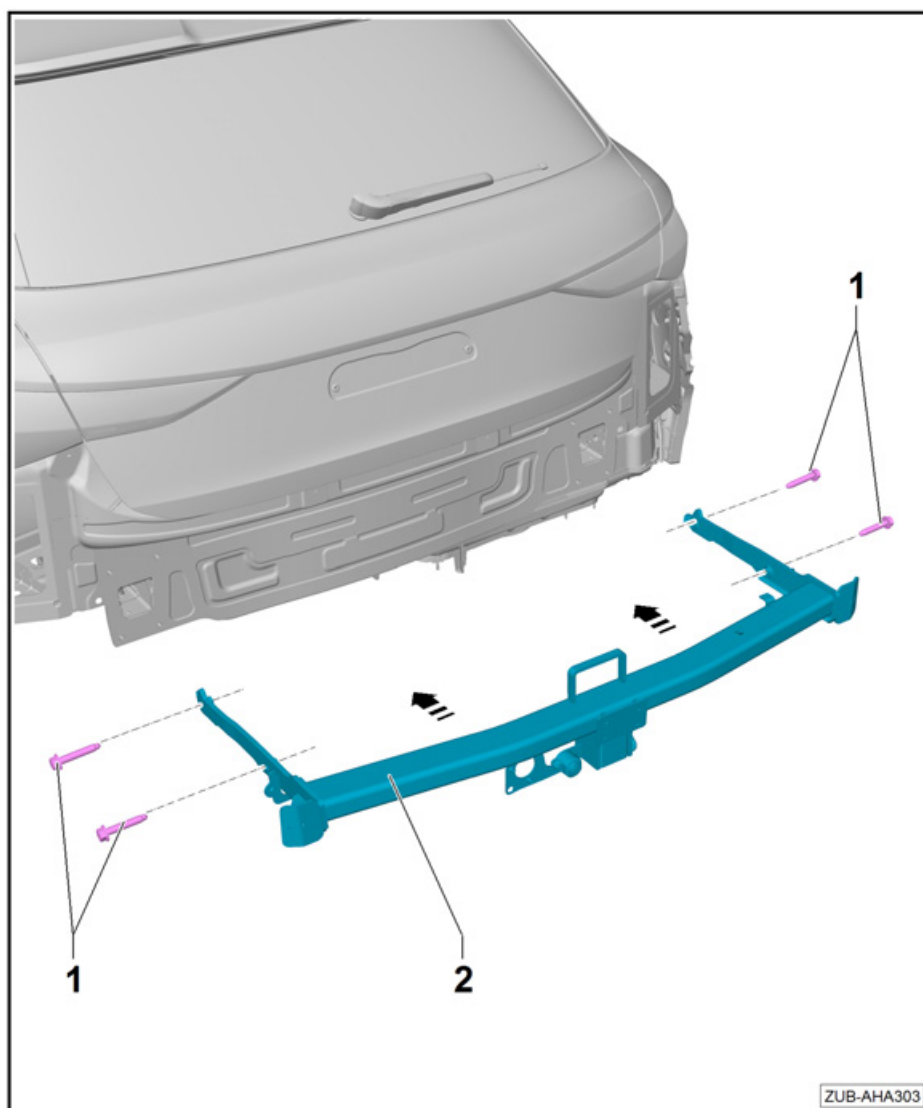

Applies to Westfalia towing bracket

1 - Securing bolts

⇒ **Page 20**

- Replace after re-
moval
- M10 x 40
- 60 Nm + 90°

2 - Trailer towing cou- pling with cross member

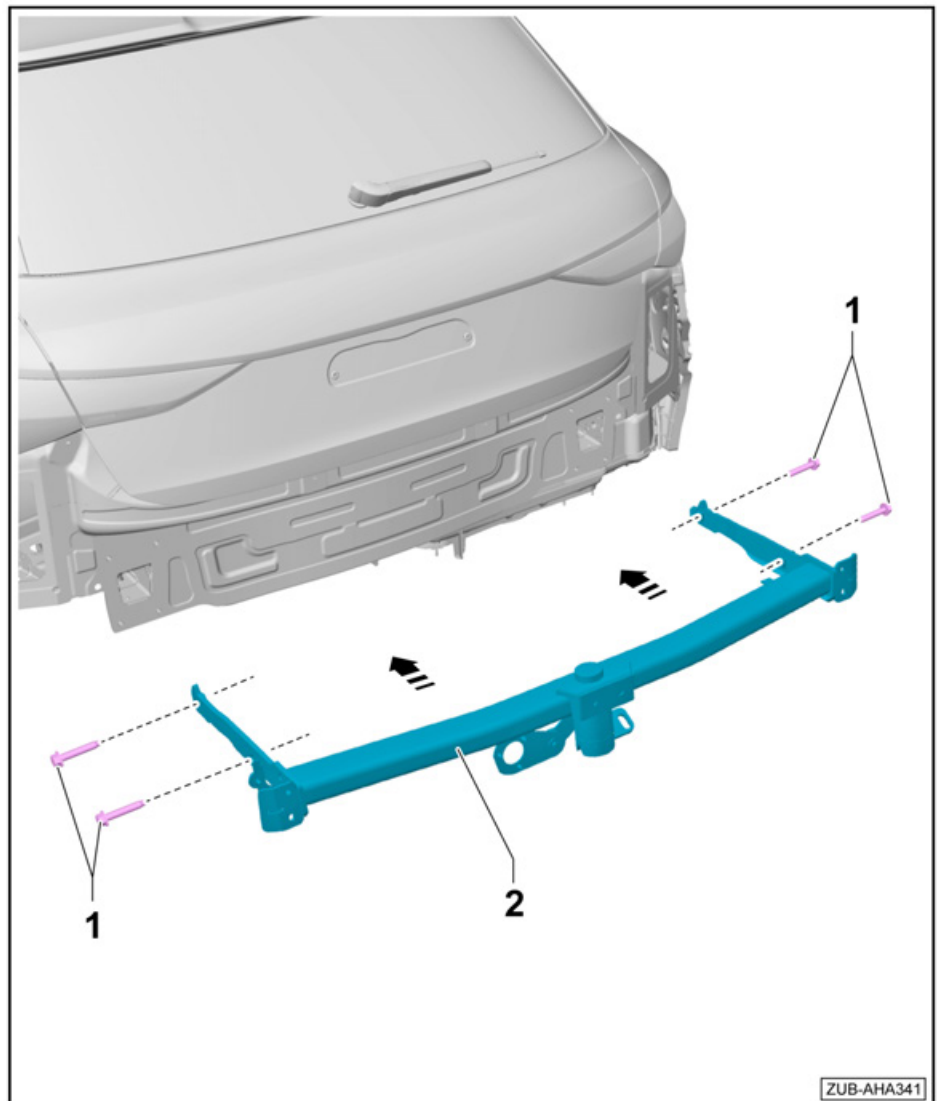



6.2 Assembly overview of the electrics

1 - Connector A on the on-board supply control unit -J519-

- CAN bus connection
- Terminal 15

2 - Connector C on the on-board supply control unit -J519-

- Brake light connection

3 - Fuse holder

- For the electrical system fuse

4 - Wiring connection for earth point on left in luggage compartment

5 - Bracket for the trailer detector control unit -J345-

6 - Fitting trailer detector control unit -J345-

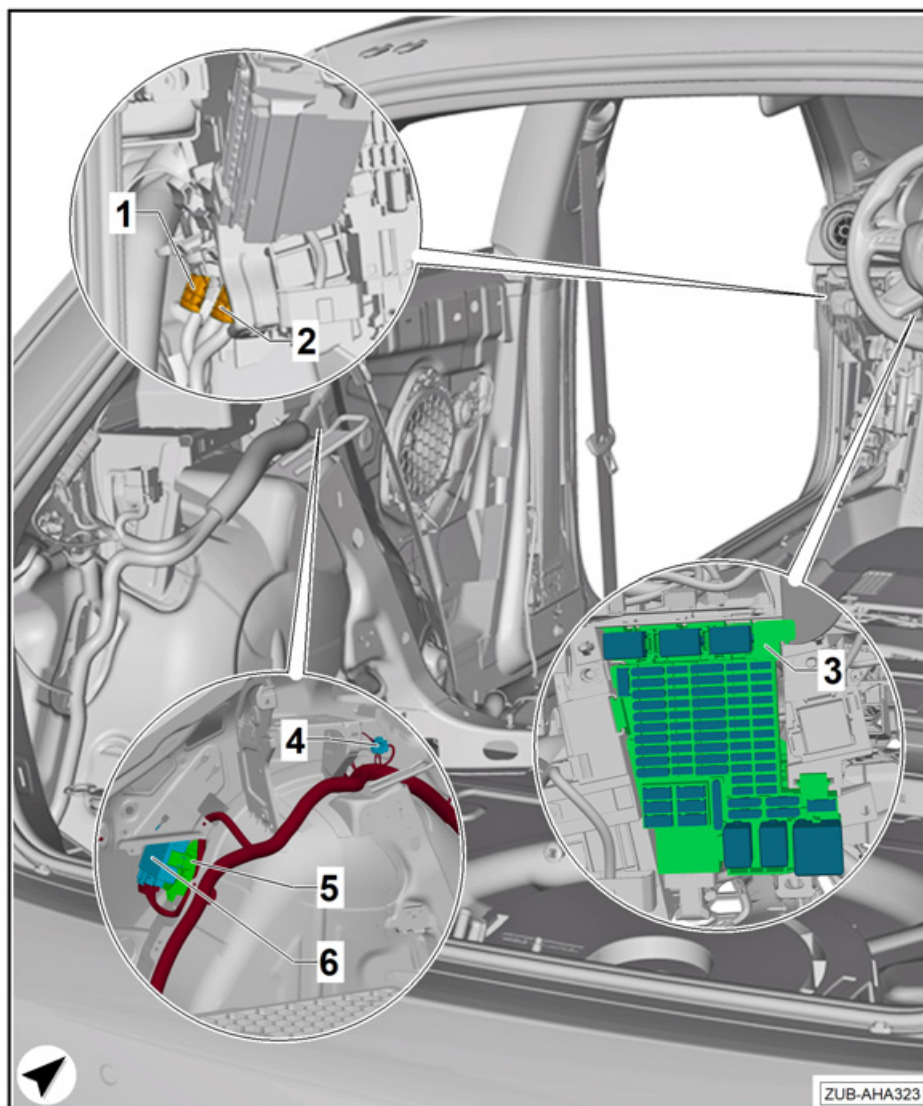



7 Fitting the towing bracket

7.1 Sealing the threaded holes and body fold on the longitudinal member of the impact damper

Special tools and workshop equipment required

- ◆ Cartridge gun for bodywork sealant
- ◆ Bodywork sealant
- ◆ Torque wrench -V.A.G 1410-

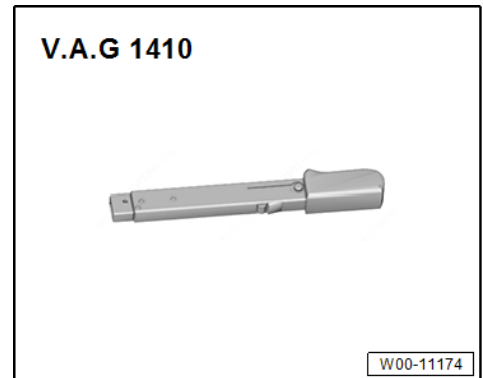

- ◆ Torque wrench -V.A.G 1332-

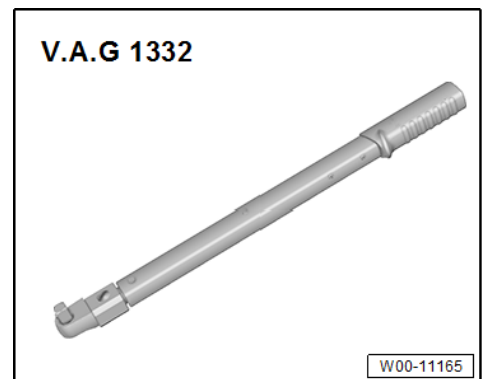

Sealing the threaded holes and body fold on the longitudinal member

Note

The threaded holes and body fold on the longitudinal member must be sealed using a suitable bodywork sealant to prevent the ingress of moisture.

- Apply bodywork sealant to securing bolts -A- and screw into the threaded holes.
- Tighten securing bolt -A- to the required torque.
- Clean the area around the body fold -B-.
- Apply bodywork sealant all around the body fold -B-.

Component	Nm
Securing bolts -A-	30

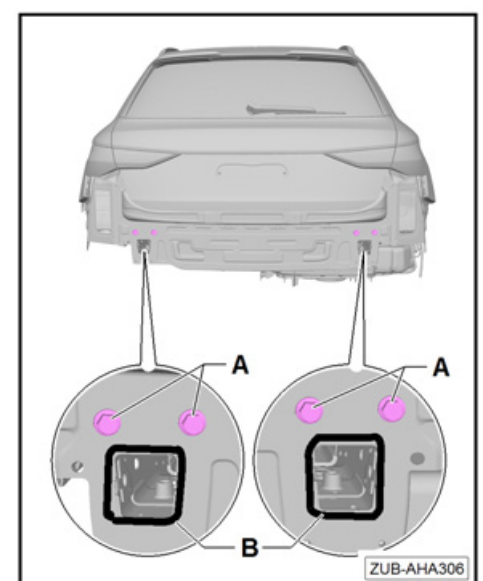



7.2 Assembling the Profsvar towing bracket

WARNING

Applies only to vehicles with SCR system without activated charcoal filter (PR no.: 1E9)

- With the help of a second mechanic, insert the trailer towing coupling with cross member -1- into the ends of the frame.

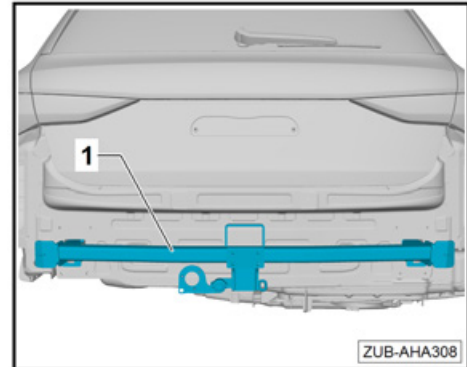

- Disconnect the SCR tank lines, see ⇒ Engine; Rep. gr. 26; SCR system; Removing and installing the reducing agent tank.
- If necessary, lower the reducing agent tank until the holes for securing the towing bracket can be accessed.

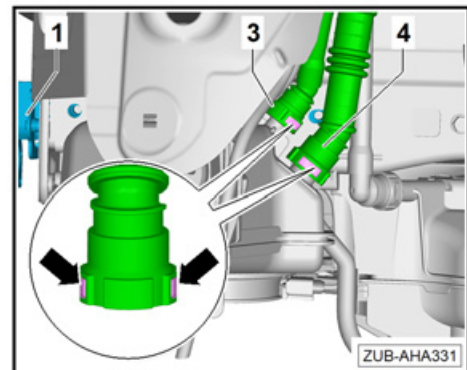

- Insert the left and right bolts -2- for securing the towing bracket -1- and tighten to the required torque ⇒ Page 16.

Caution

Reducing agent leaks are dangerous!

◆ **Note the safety precautions for handling the reducing agent ⇒ Page 3.**

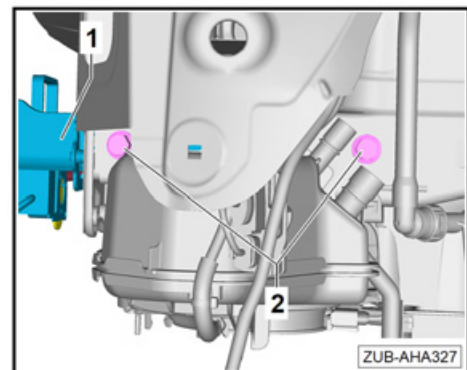

Applies to vehicles without the SCR system

- With the help of a second mechanic, insert the trailer towing coupling with cross member -1- into the ends of the frame.

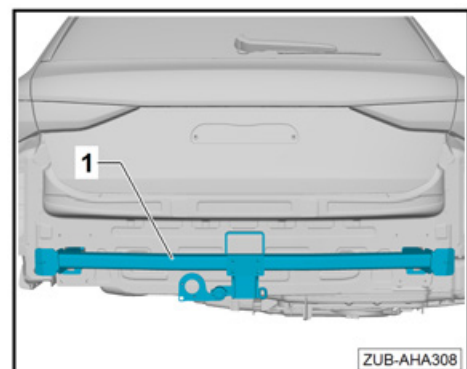



- Insert the left and right bolts -2- for securing the towing bracket -1- and tighten to the required torque ⇒ [Page 16](#).

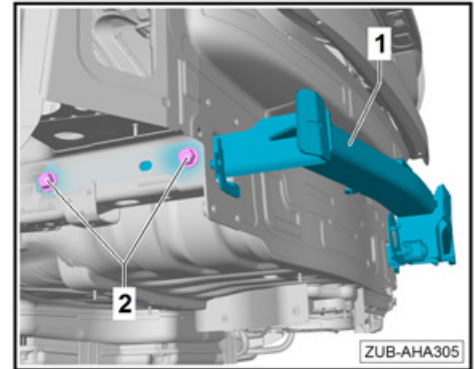

7.3 Assembling the Westfalia towing bracket

WARNING

Applies only to vehicles with SCR system without activated charcoal filter (PR no.: 1E9)

- With the help of a second mechanic, insert the trailer towing coupling with cross member -1- into the ends of the frame.
- Disconnect the SCR tank lines, see ⇒ Engine; Rep. gr. 26; SCR system; Removing and installing the reducing agent tank.
- If necessary, lower the reducing agent tank until the holes for securing the towing bracket can be accessed.

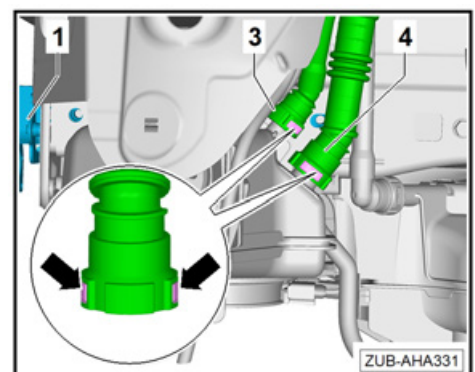
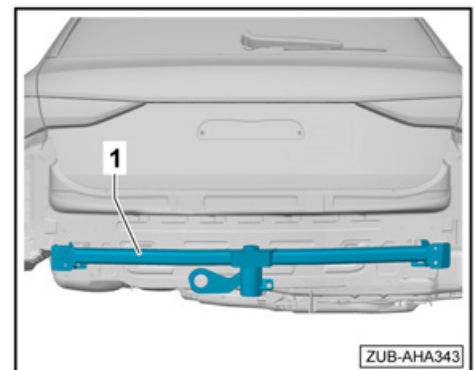



- Insert the left and right bolts -2- for securing the towing bracket -1- and tighten to the required torque ⇒ [Page 16](#).

⚠ Caution

Reducing agent leaks are dangerous!

◆ **Note the safety precautions for handling the reducing agent** ⇒ [Page 3](#).

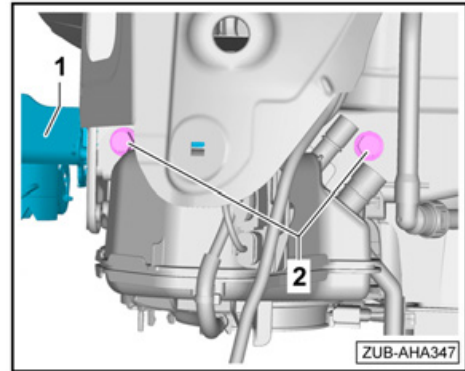

Applies to vehicles without the SCR system

- With the help of a second mechanic, insert the trailer towing coupling with cross member -1- into the ends of the frame.

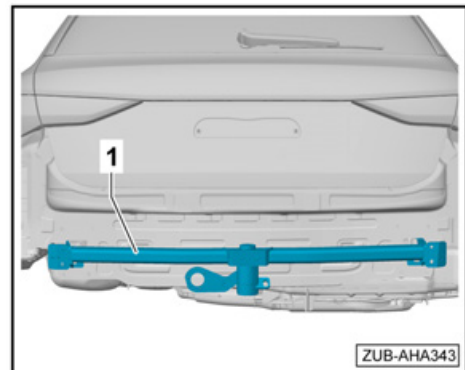

- Insert the left and right bolts -2- for securing the towing bracket -1- and tighten to the required torque ⇒ [Page 16](#).

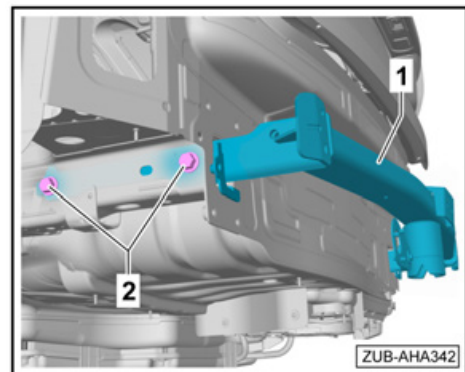

7.4 Assembling the ball coupling for the Profsvar towing bracket

- Remove the protective cover by pulling it downwards.
- Use the key -6- to open the lock -5-.
- Press the release button -4- and push the lever -3- downwards.
- Slide the ball coupling -2- upwards into the towing bracket -1-.
- The ball coupling -2- engages audibly and the lever -3- automatically snaps back up.
- Use the key -6- to lock the lock -5-. The lever -3- and the release button -4- are locked.
- Remove the key -6-.

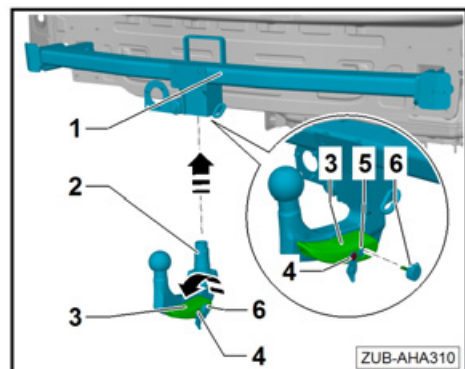



7.5 Disassembling the ball coupling for the Profsvar towing bracket

- Use the key -6- to open the lock -5-. The lever -3- is unlocked.
- Press the release button -4- and push the lever -3- downwards.
- Slide the ball coupling -2- downwards and out of the towing bracket -1-.

Note

The lever -3- remains in the -unlocked- position until the next use.

- Push the protective cover into the tow bar from below.

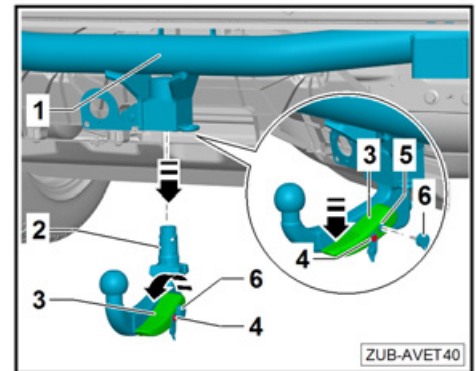

7.6 Assembling the ball coupling for the Westfalia towing bracket

- Remove the protective cover by pulling it downwards.
- Use the key -5- to open the lock -4-.
- Pull out the wheel -3- and turn it clockwise until it locks.
- Slide the ball coupling -2- upwards into the towing bracket -1-.
- The ball coupling -2- engages audibly and the wheel -3- automatically snaps back.
- Use the key -5- to lock the lock -4-. Wheel -3- is locked.
- Remove the key -5-.

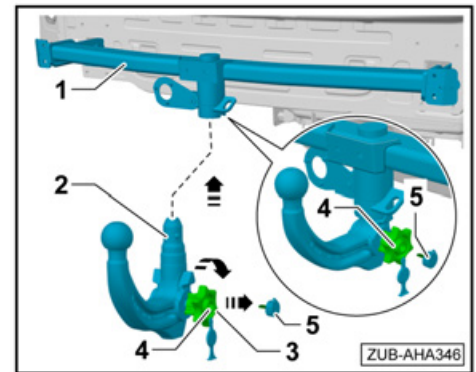

7.7 Disassembling the ball coupling for the Westfalia towing bracket

- Use the key -5- to open the lock -4-. Wheel -3- is unlocked.
- Pull out the wheel -3- and turn it clockwise.
- Slide the ball coupling -2- downwards and out of the towing bracket -1-.
- Wheel -3- remains locked.
- Key -5- remains inserted.
- Push the protective cover into the tow bar from below.
- Store the ball coupling -2- in the vehicle.

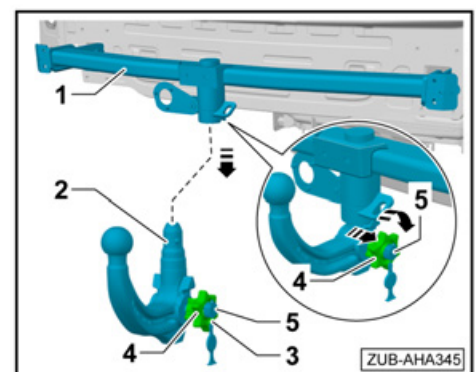



7.8 Assembling the electric socket with side outlet for the Profsvar towing bracket

- Connect the electrical connector -3- to the trailer socket -4-, making sure that the connector clicks into place.
- Feed the electrical wire -2- sideways out of the recess on the trailer socket -4-.
- Position the trailer socket -4- on the bracket -1- and secure the trailer socket using the screws -5-.

Note

Make sure that the wire can move!

- Insert the screws -5- and tighten to a tightening torque of 2 Nm.

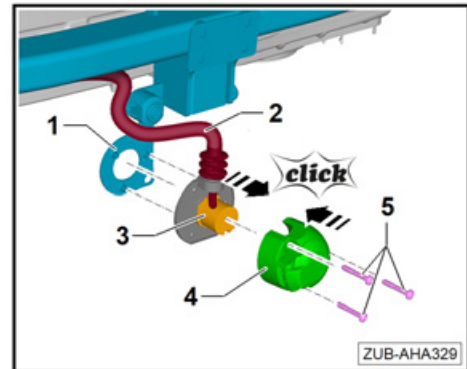

7.9 Assembling the electric socket with side outlet for Westfalia towing bracket

- Connect the electrical connector -3- to the trailer socket -4-, making sure that the connector clicks into place.
- Feed the electrical wire -2- sideways out of the recess on the trailer socket -4-.
- Position the trailer socket -4- on the bracket -1- and secure the trailer socket using the screws -5-.

Note

Make sure that the wire can move!

- Insert the screws -5- and tighten to a tightening torque of 2 Nm.

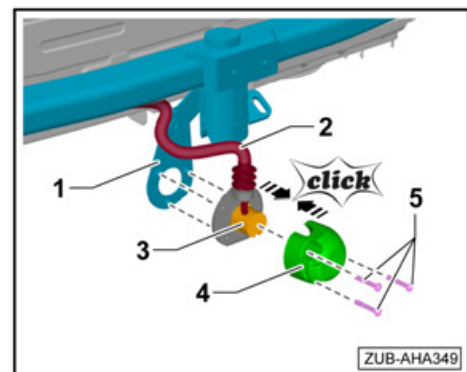

7.10 Routing the trailer socket wire to the trailer detector control unit -J345-

- Remove the sealing plug -A-.

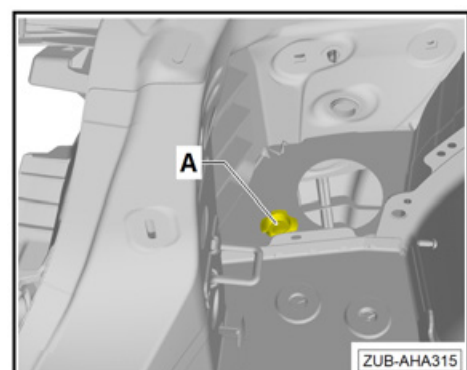



- Feed the wire for the trailer socket -3- through the hole and insert the grommet -A-.

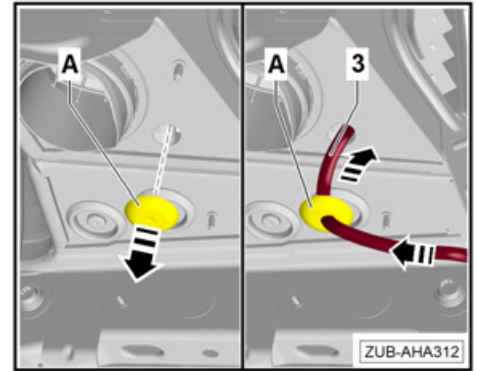



8 Electrical connection with preparation (1M5)

8.1 Installing the control unit bracket

In vehicles without a control unit bracket in the rear left-hand side of the luggage compartment, the bracket must also be installed.

- Place the bracket -1- with the securing clips -2- on the left-hand side and secure the bracket in place.

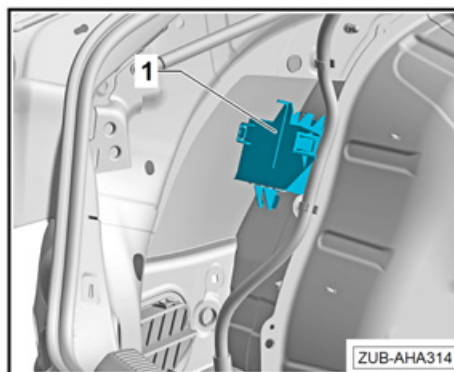

8.2 Installing the trailer detector control unit J345

- Insert the trailer detector control unit -J345- -2- into the bracket -1- -arrow-.

The trailer detector control unit -J345- -2- engages in the bracket -1-.

- Insert the bracket -1- on the left-hand side and secure it in place using the securing clips.

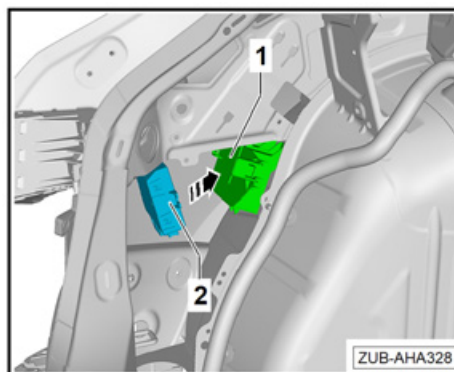



8.3 Pinning the retrofit wiring harness for the trailer socket to the connector for the trailer detector control unit -J345- and connecting the wiring harness to the trailer detector control unit -J345-

- Pin the free wires from the retrofit wiring harness for the trailer socket into the connector for the trailer detector control unit -J345- as follows:

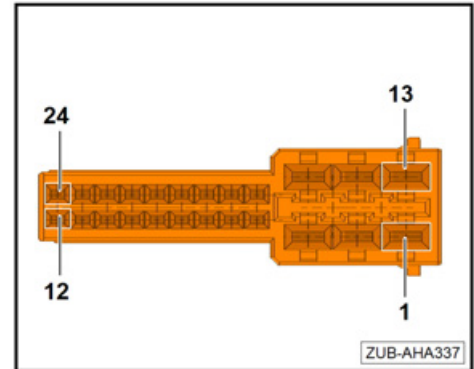

Pin assignment

Wire	cable colour	Terminal pin for socket	Pin for trailer control unit connector
Power supply for terminal 15	RD/BK	A10	A01
Battery terminal 30	RD/GN	A09	A02
Brake light	RD/BK	A06	A03
Rear fog light	GY/WH	A02	A12
Right-hand tail light cluster	GY/RD	A05	A15
Right-hand turn signal	BK/GN	A04	A18
Reversing light	BK/BL	A08	A19
Left-hand tail light cluster	GY/BK	A07	A23
Left-hand turn signal	BK/WH	A01	A24

Note

The retrofit wiring harness comes with a purple cable bridge, which must be inserted between pin A07 and pin A10 on the trailer control unit connector.

- Continue feeding in the wire for the trailer socket until it reaches the installation position of the trailer detector control unit -J345- -2-.
- Insert the connector for the towing bracket socket -5- into the trailer detector control unit -J345- -2- and fasten using the white bracket.

Note

Fix any excess wire lengths in position with a cable tie to prevent noise.

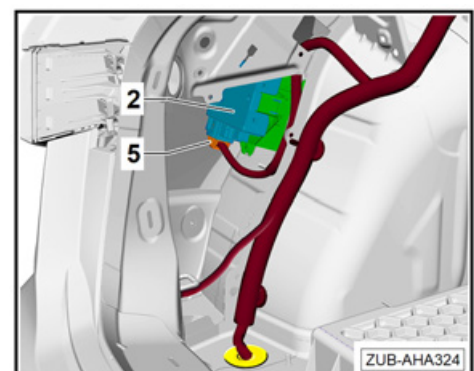



8.4 Plugging in the retrofit wiring harness for the onboard supply, CAN bus and brake light signal/terminal 15

- Connect the supply connector for the electrical system -6- and the supply connector for the CAN bus/brake light signal/terminal 15 -7- to the existing wires (1M5) on the trailer detector control unit -J345- -1-.

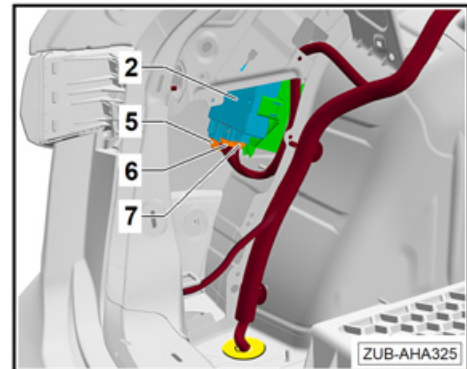

8.5 Establishing the earth connection

- Establish the earth connection at the earth point -4-.
- Secure the excess wire lengths on the standard wiring harness using cable ties.

The wires must be secured with cable ties to stop them from “slipping” or “wearing”.

Earth point tightening torque: 9 Nm

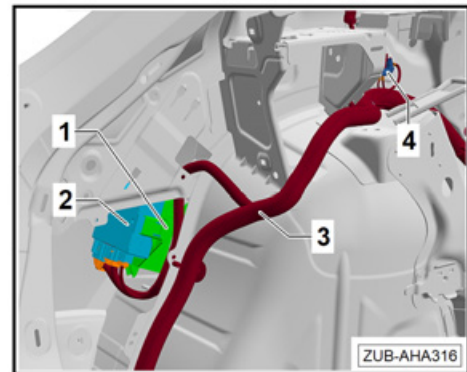

8.6 Inserting the fuses into the relay and fuse carrier

- Insert the fuses into the relay and fuse carrier -1-.
- If required, insert the fuses as follows:

Fuse location F03 (2) - Fuse: 25 A

Fuse location F29 (3) - Fuse: 15 A

Fuse location F31 (4) - Fuse: 25 A

Fuse location F11 (5) - Fuse: 15 A

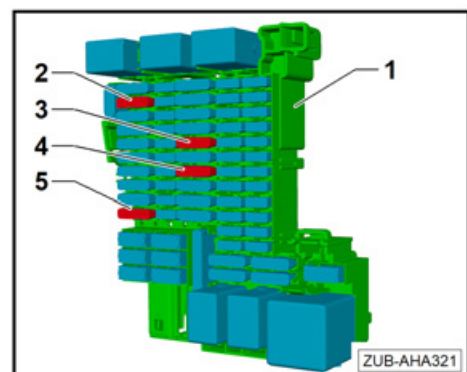



8.7 Connecting the CAN bus

Applies to vehicles with towing bracket preparation (1M5)

Note

The CAN bus connector -1- is located in the footwell on the lower section of the left-hand A-pillar under the interior trim (this space can vary due to structural conditions) and is integrated into the standard wiring harness.

- Connect the CAN bus connector -1- magnifying glass-.
Check for secure engagement.

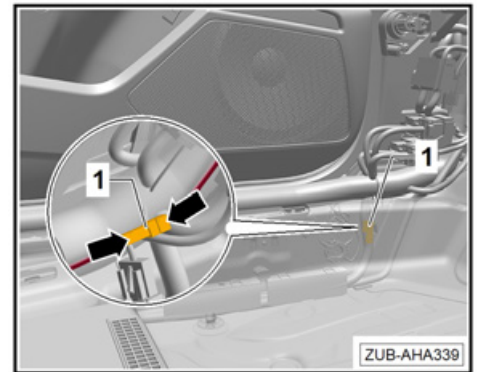



9 Electrical connection without preparation (1D0)

9.1 Installing the control unit bracket

In vehicles without a control unit bracket on the rear left-hand side of the luggage compartment, the bracket must also be ordered and installed.

- Place the bracket -1- with the securing clips -2- on the left-hand side and secure the bracket in place.

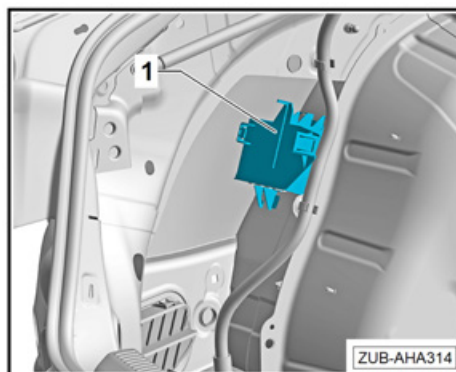

9.2 Installing the trailer detector control unit J345

- Insert the trailer detector control unit -J345- -2- into the bracket -1- -arrow-.

The trailer detector control unit -J345- -2- engages in the bracket -1-.

- Insert the bracket -1- on the left-hand side and secure it in place using the securing clips.

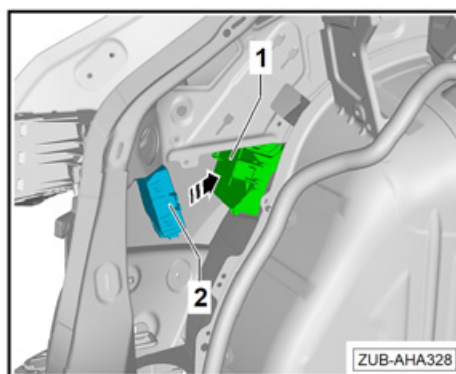



9.3 Pinning the retrofit wiring harness for the trailer socket to the connector for the trailer detector control unit -J345- and connecting the wiring harness to the trailer detector control unit -J345-

- Pin the free wires from the retrofit wiring harness for the trailer socket into the connector for the trailer detector control unit -J345- as follows:

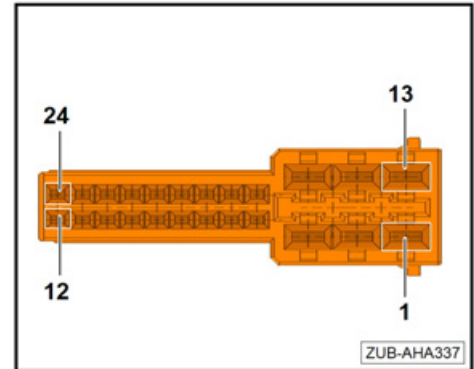

Pin assignment

Wire	cable colour	Terminal pin for socket	Pin for trailer control unit connector
Power supply for terminal 15	RD/BK	A10	A01
Battery terminal 30	RD/GN	A09	A02
Brake light	RD/BK	A06	A03
Rear fog light	GY/WH	A02	A12
Right-hand tail light cluster	GY/RD	A05	A15
Right-hand turn signal	BK/GN	A04	A18
Reversing light	BK/BL	A08	A19
Left-hand tail light cluster	GY/BK	A07	A23
Left-hand turn signal	BK/WH	A01	A24

Note

The retrofit wiring harness comes with a purple cable bridge, which must be inserted between pin A07 and pin A10 on the trailer control unit connector.

- Continue feeding in the wire for the trailer socket until it reaches the installation position of the trailer detector control unit -J345- -2-.
- Insert the connector for the towing bracket socket -5- into the trailer detector control unit -J345- -2- and fasten using the white bracket.

Note

Fix any excess wire lengths in position with a cable tie to prevent noise.

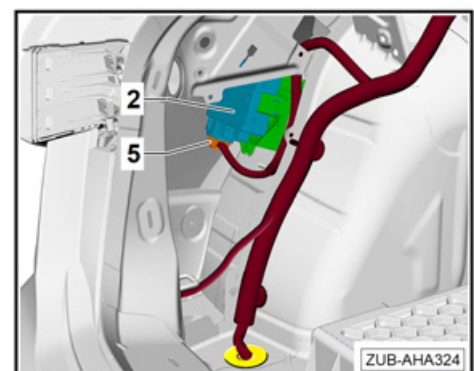



9.4 Plugging in the retrofit wiring harness for the onboard supply, CAN bus and brake light signal/terminal 15

- Connect the supply connector for the electrical system -6- and the supply connector for the CAN bus/brake light signal/terminal 15 -7- from the retrofit wiring harness for the electrical system on the trailer detector control unit -J345- -1-.

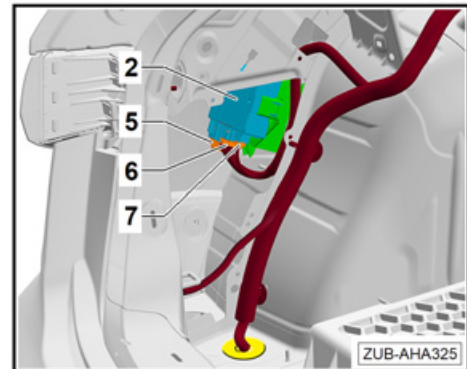

9.5 Installing the onboard supply retrofit wiring harness

The “on-board supply” retrofit wiring harness is only installed on vehicles without the preparation for towing bracket.

Installation

- Route the on-board supply retrofit wiring harness -3- along the standard wiring harness to the trailer detector control unit -J345- -2- and connect the wiring harness to the trailer detector control unit.
- Establish the earth connection -4-.
- Secure the retrofit wiring harness -3- to the standard wiring harness using cable ties.

The wires must be secured with cable ties to stop them from “slipping” or “wearing”.

- Route the retrofit wiring harness -3- along the standard wiring harness to the relay and fuse carrier behind the shelf on the front passenger side. On right-hand drive vehicles, the fuse carrier is located behind the glove box.
- Secure the retrofit wiring harness -3- to the standard wiring harness using cable ties.

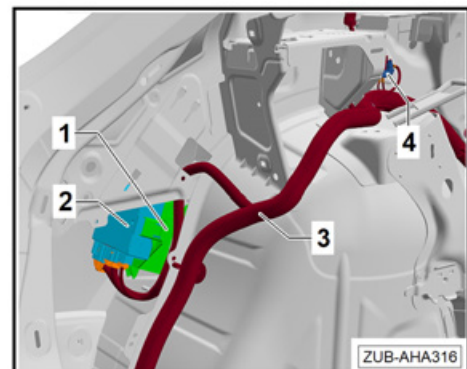

Notes on further installation

Earth point tightening torque: 9 Nm



9.6 Removing the relay and fuse carrier

Removal

- Press the spring catches -arrows- and remove the relay and fuse carrier -1- from the bracket.

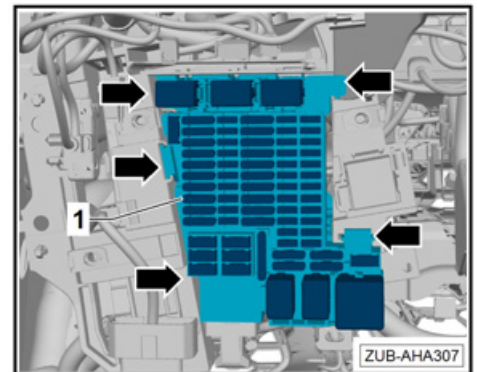

9.7 Establishing the power supply to terminal 30

Terminal 30 is supplied directly via the relay and fuse carrier -1-.

- Insert the following list of wires from the retrofit wiring harness into the respective slots on the relay and fuse carrier -1-, making sure that the wires click into place.

Red/green wire (2) - Slot 03A

Red wire (3) - Slot 29A

Red/yellow wire (4) - Slot 31A

Red/white wire (5) - Slot 11A

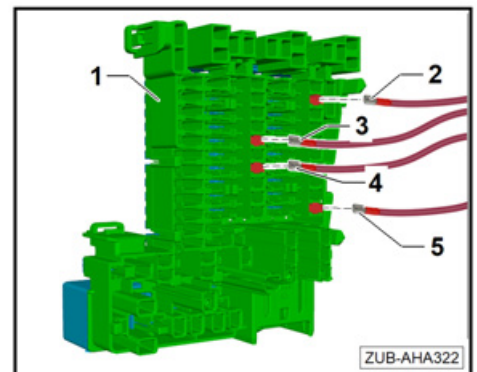

- Insert the fuses into the relay and fuse carrier -1-.

Fuse location F03 (2) - Fuse: 25 A

Fuse location F29 (3) - Fuse: 15 A

Fuse location F31 (4) - Fuse: 25 A

Fuse location F11 (5) - Fuse: 15 A

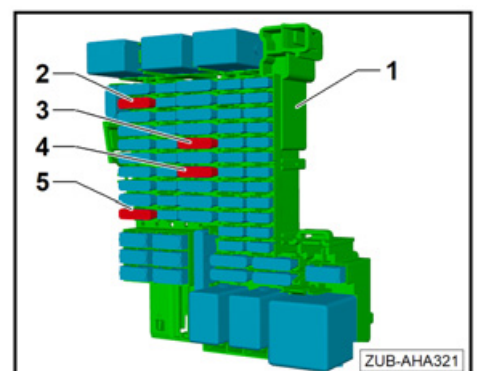

9.8 Connecting the CAN bus/terminal 15 brake light signal

Installing the wire for the CAN bus/terminal 15 (connector A)

The CAN bus/terminal 15 brake light signal is connected to the on-board supply control unit -J519- behind the dash panel cover on the driver side on left-hand drive vehicles/behind the glove compartment on right-hand drive vehicles. Connectors A and C on the on-board supply control unit -J519- are used.



- Release and disconnect connector A -1- on the onboard supply control unit -J519-.

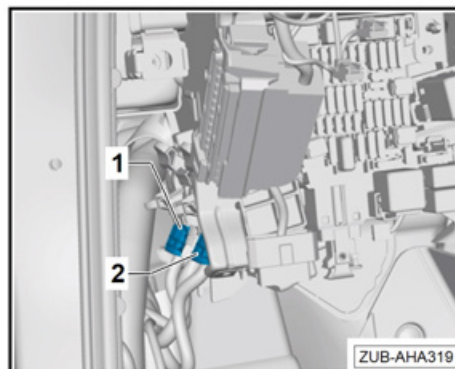

- Open the connector housing and unpin contacts 14, 16 and 17.

- Pin the corresponding contacts of the retrofit wiring harness (Y-wire) into connector A.

- ◆ Pin 14: terminal 15, black/violet
- ◆ Pin 16: CAN bus High, green
- ◆ Pin 17: CAN bus low, orange/brown

- Pin contacts 14, 16 and 17 from connector A into the loose black 3-pin contact housing.

Pin 1 - Terminal 15, black/violet

Pin 2 - CAN bus High, green

Pin 3 - CAN bus low, orange/brown

- Connect the black 3-pin connector housing that was just pinned to the corresponding black 3-pin connector housing on the retrofit wiring harness.

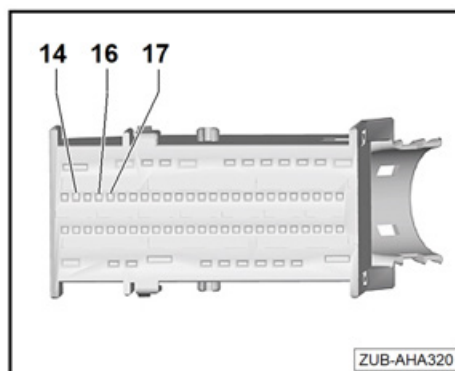

Installing the wire for the brake light signal (connector C)

- Release and disconnect connector C -2- on the onboard supply control unit -J519-.

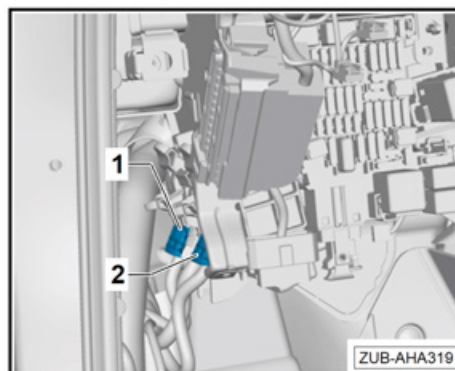



- Open the connector housing and unpin contact 58.
- Pin the corresponding contact of the retrofit wiring harness (Y-wire) into connector C.
- ◆ Pin 58: brake light, black/red
- Pin the contact 58 from connector C into the loose black three-pin connector housing of chamber 2.
- Connect the black 3-pin connector housing that was just pinned in chamber 2 to the corresponding black 3-pin connector housing on the retrofit wiring harness (only the one in chamber 2).

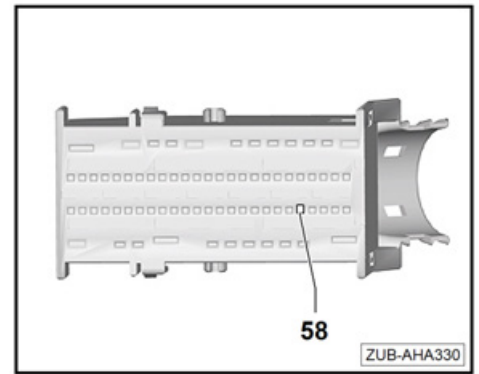



10 Concluding operations

10.1 Reassembling the vehicle

To install the components, follow the removal steps in reverse order. Observe the "Notes on installation" for the relevant components and the corresponding tightening torques.

On vehicles with lane change assist, this must be recalibrated.

WARNING

The following information must be observed when working with the lane change assist (Audi side assist):

- ◆ ***If the rear bumper cover is removed and then reinstalled, or if any modifications are made to the rear bumper cover, the lane change assist system (Audi side assist) must be recalibrated ⇒ Electrical system; Rep. gr. 96; Risk of accident due to malfunction!***

10.2 Connecting the battery

- Workshop Manual ⇒ Electrical system; Rep. gr. 27; Disconnecting and connecting the battery

Note

After reconnecting the power supply, the ESP warning light can only extinguish after a few metres have been driven.

10.3 Adapting the trailer detector control unit -J345- activation process

The activation process is carried out using the ⇒ vehicle diagnostic tester. This must be connected online.

WARNING

Before you start the activation process, go into the self-diagnosis function and check that it is possible to contact the DA69 (towing bracket control unit); this ensures that the CAN bus is connected. ⇒ Page 29

Enter the "clear error" (Fehler löschen) command for the DA69 in the self-diagnosis function; by doing so, you can identify whether all power supplies and the earth are present; if the result is positive, you can continue; if the result is negative, check all power supplies as well as the fuse and contacts!

If this is not done, you will receive result code FFP0707E.

10.4 Functional check on the socket

- Check that the trailer socket -U10- functions correctly using the trailer socket tester -VAS 5800- or a trailer.



Pin assignment in the trailer socket -U10-.

- 1 - Terminal LTS (left turn signal)
- 2 - Terminal RFL (rear fog light)
- 3 - Terminal 31 (earth) earth for terminals 1–2, 4–8
- 4 - Terminal RTS (right turn signal)
- 5 - Terminal 58 R (right tail light)
- 6 - Terminal 54 (brake light)
- 7 - Terminal 58 L (left tail light)
- 8 - Terminal RVL (reversing light)
- 9 - Terminal 30 (battery "+") max. current 15 A
- 10 - Terminal 15 (charging cable) max. current 15 A
- 11 - Terminal 31 (earth) earth for terminal 10
- 12 - Not assigned
- 13 - Terminal 31 (earth) earth for terminal 9

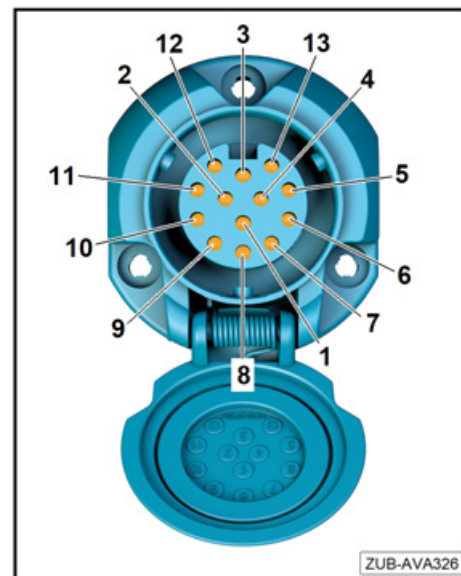

10.5 Reassembling the vehicle

The vehicle is assembled in the reverse order. Read and observe the notes on installation for the relevant components and the corresponding tightening torques.

On vehicles with lane change assist, this must be recalibrated.

WARNING

The following information must be observed when working with the lane change assist (Audi side assist):

- ◆ **If the rear bumper cover is removed and then reinstalled, or if any modifications are made to the rear bumper cover, the lane change assist system (Audi side assist) must be recalibrated ⇒ Electrical system; Rep. gr. 96; Risk of accident due to malfunction!**

With regard to vehicles fitted with a rear view camera, observe the following:

- ◆ **If the rear bumper cover is removed and then reinstalled, or if any modifications are made to the rear bumper cover, the rear view camera system must be calibrated ⇒ Electrical system; Rep. gr. 91; Calibrate the rear view camera system!**

- Once assembled, check the towing bracket functions correctly ⇒ Owner's Manual.



10.6 Finishing the assembly work for the Profsvar towing bracket

- Attach the sticker provided -1- to a clean surface in a prominent position.

Note

Bonding surfaces must be dry and free of dust and grease!

The maximum trailer weight or trailer drawbar load in kg for the towing bracket of the manufacturer Westfalia can be found in the ⇒ Vehicle registration certificate/Owner's Manual of your vehicle.

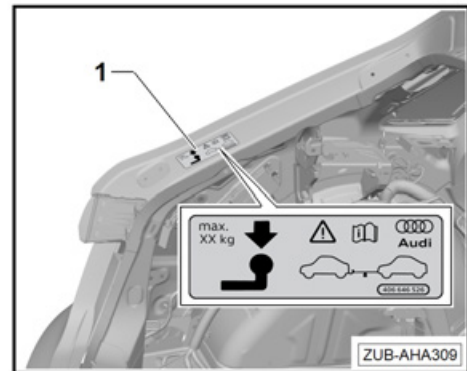

10.7 Adjusting the cooling system

As towing mode puts greater demands on the engine cooling system, the cooling system is upgraded – where technically possible – when the towing bracket is installed in the factory.

The cooling system does not need to be upgraded if it is possible to guarantee that the engine is only ever exposed to the following conditions:

- ◆ The permissible gross combination weight is underrun
- ◆ No high ambient temperatures
- ◆ No long, steep inclines
- ◆ No high altitude journeys

In any case, the coolant temperature display must be carefully monitored. If the needle in the display moves into the hot area, the speed must be reduced immediately. A cool-down time must also be allowed for if necessary. This involves the allowing the engine to idle for approx. 2 minutes to prevent a build-up of heat.