

Installation instructions

AUDI Q5 (FY) 2017 ►

AUDI Q5 (PU) (FY) 2021 ►

AUDI Q5 Sportback (FY) 2021 ►

**Fixed/mechanically removable towing bracket
with electrics set (NAR)**

for package number 80A.092.115.*

Audi Genuine Accessories

Edition 03



Contents

1	General notes	1
2	Safety instructions for pyrotechnical, electrical and mechanical components of the restraint system	2
2.1	General safety instructions	2
2.2	Storing, transporting and disposing of airbag, belt tensioner and battery disconnecter units (pyrotechnic components)	3
3	Safety notes on the towing bracket – Fitting and operation	4
3.1	Notes on the towing vehicle	4
3.2	Notes on the towing bracket	4
3.3	Safety notes on assembly	5
3.4	Safety notes on operation	6
4	Overview of components	7
4.1	Overview of mechanical components	7
4.2	Overview of electrical system components	8
4.3	Additional required parts	8
5	Assembly overview and tightening torques	10
5.1	Towing bracket with cross member	10
5.2	Luggage compartment electrical system	11
6	Preparations	12
6.1	Disconnecting the battery	13
6.2	Removing the following equipment	13
7	Installing the towing bracket	15
7.1	Fitting the towing bracket	15
7.2	Installing the towing bracket	15
7.3	Connector panel assembly	16
8	Electrical connection	17
8.1	Fitting the socket with retrofit wiring harness to the connector panel	17
8.2	Installing the bracket for the trailer detector control unit -J345-	17
8.3	Routing and connecting the socket retrofit wiring harness	17
8.4	Connecting the supply line for the brake booster	19
8.4.1	Workflow for variant 1	19
8.4.2	Workflow for variant 2	20
9	Concluding operations	21
9.1	Reassembling the vehicle	21
9.2	Connecting the battery	21
9.3	Adapting the trailer detector control unit -J345- coding	21
9.4	Commissioning and functional check	21



9.5	Adjusting the cooling system	22
-----	------------------------------------	----







1 General notes

Please read and take note of these WARNING, Caution and Note descriptions before carrying out maintenance or repair work.



WARNING

Text with this symbol contains information concerning your safety and indicates potential accident and injury risks.



Caution

Text with this symbol indicates the risk of damage to your vehicle.



Note

Text with this symbol contains additional information.



Caution

Towing mode places increased demands on the cooling system.

- ◆ ***The cooling system ⇒ Page 22 must be adapted to the vehicle operating conditions .***

Special tools are required for assembly. Improper installation can cause damage to the vehicle or the add-on parts.



WARNING

For safety reasons, the towing bracket must only be fitted by skilled personnel – risk of accident!

Additional modifications may be required – risk of accident. Detailed information can be found in these installation instructions.

AUDI AG shall not accept responsibility in the event of failure to comply with these installation instructions.



2 Safety instructions for pyrotechnical, electrical and mechanical components of the restraint system

2.1 General safety instructions

Pyrotechnical components comprise:

- ◆ Airbag units
- ◆ Belt tensioners
- ◆ Belt force limiters
- ◆ Battery disconnecting elements

General

- ◆ Testing, installation and maintenance tasks must only be carried out by trained personnel.
- ◆ There are no replacement intervals for airbag units.
- ◆ Do not check using circuit tester, voltmeter, or ohmmeter under any circumstances.
- ◆ Pyrotechnic components must only be checked when installed and using ⇒ vehicle diagnostic testers that have been approved by the manufacturer.
- ◆ When working on pyrotechnic components and the airbag control unit -J234-, the battery earth wire must be disconnected when the IGNITION is SWITCHED ON. The battery negative terminal must subsequently be covered.
- ◆ You must wait ten seconds after the battery -A- has been disconnected.
- ◆ The battery -A- must be connected when the IGNITION is SWITCHED ON. There must not be anybody inside the vehicle during this process. Exception: vehicles with battery -A- located inside the vehicle. Do not sit within the airbag and seat belt deployment range.
- ◆ Observe the appropriate steps after connecting the battery ⇒ [Page 21](#).
- ◆ Before performing any work on pyrotechnic components in the restraint system, e.g. before disconnecting the electrical connector, the mechanic carrying out the task must discharge any static electricity. Electrostatic discharging can be performed by touching earthed metal parts, e.g. by briefly touching the door striker plate.
- ◆ Wash hands after touching ignited pyrotechnical components of the restraint system.
- ◆ Pyrotechnical components must neither be opened nor repaired. New parts must always be used (risk of injury).
- ◆ Pyrotechnic components that have fallen onto a hard surface or that show any sign of damage must not be installed.



- ◆ Pyrotechnic components must be installed immediately after they are removed from the transport container.
- ◆ If work is interrupted, the pyrotechnic component must be returned to the transport container.
- ◆ Pyrotechnic components must not be left unattended.
- ◆ When connecting the pyrotechnic components in the restraint system, only the person performing the work may be inside the vehicle.
- ◆ Pyrotechnic components must not be treated with grease, cleaning agents or similar products.
- ◆ If the fabric becomes contaminated with substances such as oil, grease, paint, colour or solvents, the airbag unit must be replaced.
- ◆ In addition, pyrotechnic components must not be exposed to temperatures above 100°C, even for short periods.

2.2 Storing, transporting and disposing of airbag, belt tensioner and battery disconnecter units (pyrotechnic components)

- ◆ Storage is subject to the applicable national legislation.
- ◆ Transportation is subject to national and international laws governing packaging, naming, labelling and accompanying documentation.
- ◆ Pyrotechnic components that have not been ignited must be returned in the original packaging for appropriate recycling in line with the applicable national legislation! Contact your importer if you have any questions.
- ◆ Only pyrotechnic components that have been completely ignited may be disposed of as industrial waste.

WARNING

This does not apply for belt tensioners that operate according to the Wankel tensioner principle. Tensioners of this kind should be handled in the same way as pyrotechnic components that have not been ignited (e.g. airbags).

Background: For belt tensioners that operate according to the Wankel tensioner principle, it is not possible to check whether all ignition stages have completed using workshop tools.



3 Safety notes on the towing bracket – Fitting and operation

3.1 Notes on the towing vehicle

Manufacturer: AUDI AG
 Model: Q5 2017 ►, Q5 (PU) 2021 ►, Q5 Sportback 2021 ►
 Offic. Type designation: FY

Maximum trailer weight or trailer drawbar load in kg, as specified by the manufacturer for the above-named vehicle model: ⇒ Vehicle registration certificate/Owner's Manual.

3.2 Notes on the towing bracket

Technical data	Vehicles with steel-spring suspension/air suspension
Bosal type:	E555
Audi part no.:	80A.800.497.*
Bosal part no.:	10027740 with connector panel NAR
D-value:	12.6 kN
Perm. drawbar load:	200 kg



WARNING

The drawbar load figures specified on the towing bracket identification plate are only given as test values. Vehicle-specific figures are often lower than these values and can be found in the vehicle documents.

Please see your vehicle documents for your maximum trailer weight.



WARNING

Do not exceed the verified D-value and the permitted trailer drawbar load – risk of accident!

The towing bracket is intended for towing trailers fitted with a tow ball and for operating carriers suitable for mounting to the coupling ball.

Nationally applicable regulations must be adhered to in EU and non-EU countries.

Improper use is prohibited.

Use is only permitted under favourable road conditions and must be adapted to road conditions.



3.3 Safety notes on assembly

 **WARNING**

For safety reasons, the towing bracket must only be fitted by skilled personnel – risk of accident!

- ◆ ***If replacement parts are required, these must only be installed by skilled personnel and to undamaged genuine parts – risk of accident!***
- ◆ ***Installation must be in line with AUDI AG/Volkswagen AG guidelines – risk of accident!***
- ◆ ***Modification of the towing bracket is prohibited. This will invalidate the type approval – risk of accident and legal implications!***
- ◆ ***Use of the mounting points approved as standard by the vehicle manufacturer is mandatory – risk of accident!***

 **Caution**

Towing mode places increased demands on the cooling system.

- ◆ ***Consult a qualified AUDI AG/Volkswagen AG workshop should modifications to the cooling system be required. Further notes can be found in the “towing mode” guidebook.***
- Remove underbody sealing, body cavity sealant (wax) or insulation material from the area around the contact surfaces of the towing bracket with the vehicle.
- In order to provide adequate corrosion protection to bare metal body parts, apply the following products with a brush.
 - ◆ Single-component primer surfacer LGF.008.001.42/43
 - ◆ Two-component HS vario surfacer LGF.786.004.A4
 - ◆ Paint to match the vehicle colour
 - ◆ Body cavity preserving agent D.330.KD2.A1



3.4 Safety notes on operation

 **WARNING**

Vehicle handling is affected by the use of towing mode; increased driver awareness is required – risk of accident!

- ◆ ***Read the notes in the “Towing mode” chapter of the ⇒ Owner's Manual – risk of accident!***
- ◆ ***If you are using trailer stabilisers, the coupling ball must be free from grease. Read and observe the notes in the relevant Owner's Manuals – risk of accident!***

The diameter of the ball coupling must be checked at regular intervals.

- ◆ ***For safety reasons, use of the towing bracket must be discontinued if the diameter reaches 49 mm at any point. If this situation occurs, contact a qualified workshop – risk of accident!***

For safety reasons, you are advised to remove the ball rod when not in use – risk of accident!



4 Overview of components

4.1 Overview of mechanical components

- 1 - Towing bracket with cross member
 - 1x
- 2 - Cover
 - 1x
- 3 - "Type plate" sticker
 - 1x
- 4 - Connector panel for trailer socket with type plate
 - 1x
- 5 - Hexagon socket head bolt for connector panel
 - M5x12
 - 2x
- 6 - Bolt with washer for towing bracket
 - M10 x 45
 - 60 Nm + 90°
 - 4x

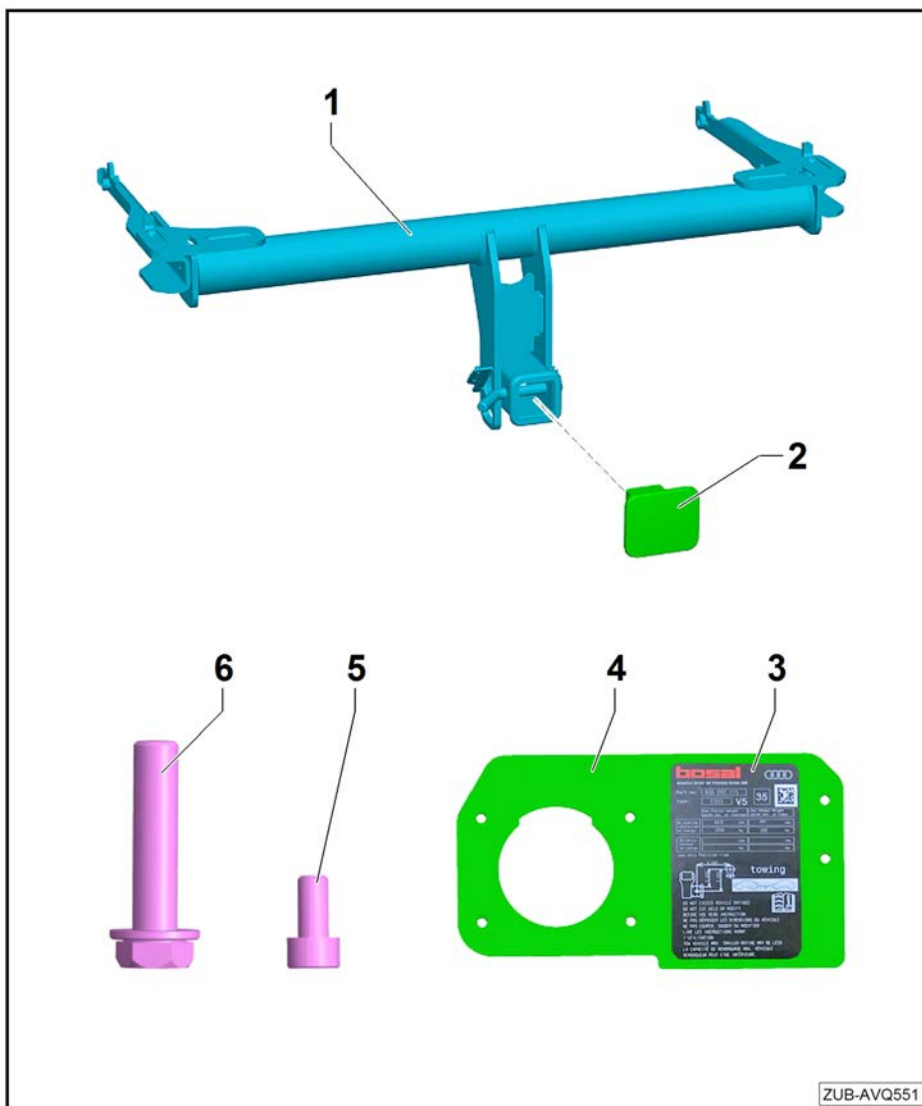

Note

The ball mount is not included in delivery of the towing bracket.



4.2 Overview of electrical system components

1 - Fitting trailer detector control unit -J345-

□ 1x

2 - Socket

□ 7-pin

□ 1x

3 - Retrofit electrical socket wiring harness

□ 1x

4 - Activation document

□ 1x

5 - Safety information sheet

□ 1x

6 - Adhesive spots

□ 4x

7 - Cable ties

□ 2x long

□ 5x short

8 - Securing bolt for the socket

□ 4x

□ 2.5 Nm

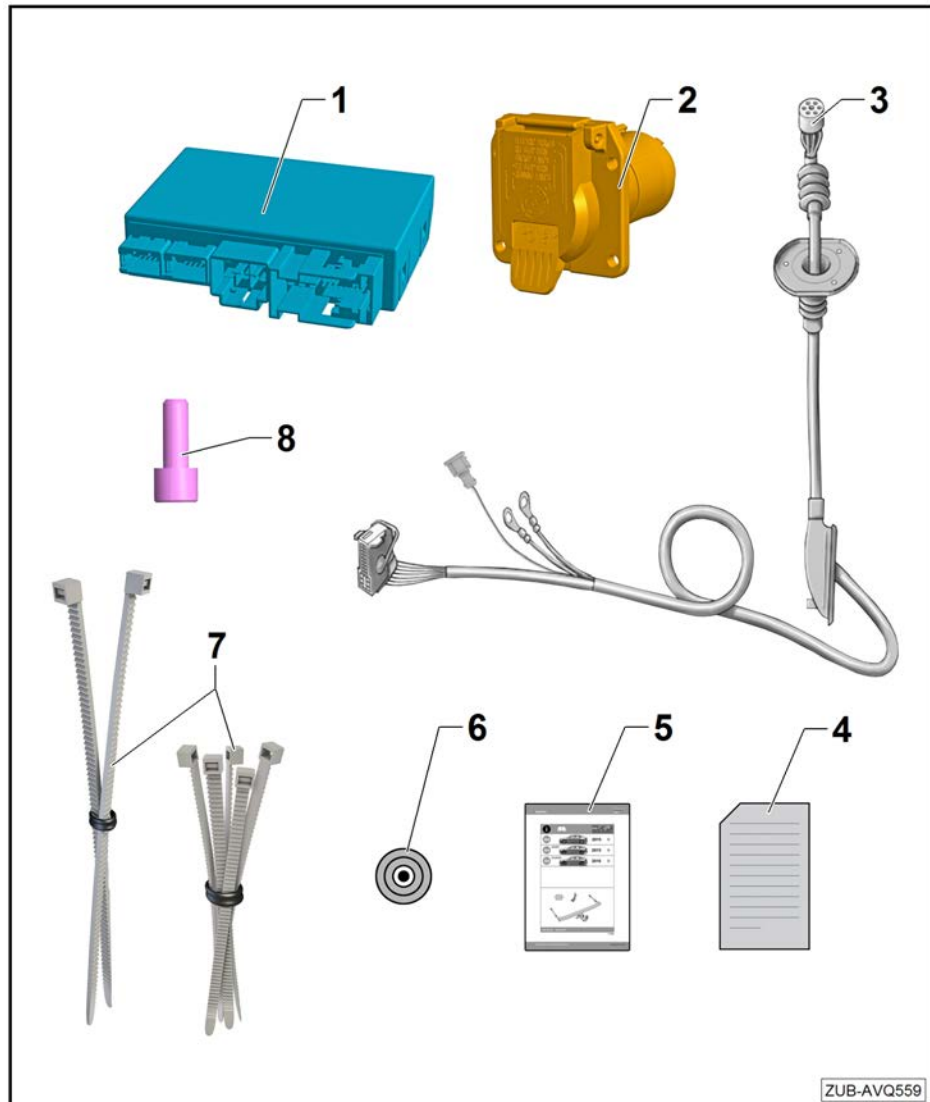

4.3 Additional required parts

Order and fit on vehicles with 1D0+KA0/KA2 or 1D8+KA0/KA2:

Bracket 80A.907.297 -1-→ Electronic parts catalogue

Order and fit according to equipment:

Note

Before ordering, check whether the bumper has a recess (on vehicles with preparation) for the towing bracket.

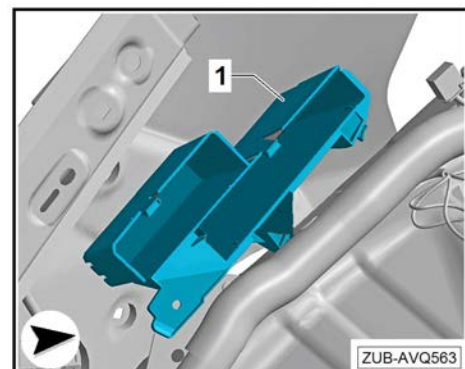



Applies to Q5 2017 ►

Bumper fitted without towing bracket	Replace with:
80A.807.521.B BASIC (2K5/2K6/VJ1/VJ5/VJ8)	80A.807.434.C (= 80A.807.521.C + 80A.807.941.B)
80A.807.521. BASIC (2K1)	80A.807.434.A (= 80A.807.521.A + 80A.807.941.B)
80A.807.521.D S-LINE/S (2K3/2K7)	80A.807.434.E (= 80A.807.521.E + 80A.807.941.A)

Applies to Q5 (PU) 2021 ►

Bumper fitted without towing bracket	Replace with:
80A.807.434.F S-LINE/S (2K3/2K7/2K8/2K9)	80A.807.434.G (= 80A.807.521.H + 80A.807.941.C)

 Note

The complete bottom part of the bumper must be replaced and painted!

Bottom part of the bumper ⇒ Electronic parts catalogue



5 Assembly overview and tightening torques

5.1 Towing bracket with cross member

1 - Towing bracket with cross member

- Assembly
- ⇒ Page 15

2 - Bolt with washer

- M10 x 45
- 60 Nm + 90°
- 4x
- Replace after removal.

3 - Hexagon socket head bolt

- M5x12
- 2x
- 5 Nm

4 - Connector panel for trailer socket with type plate

- Assembly
- 1x

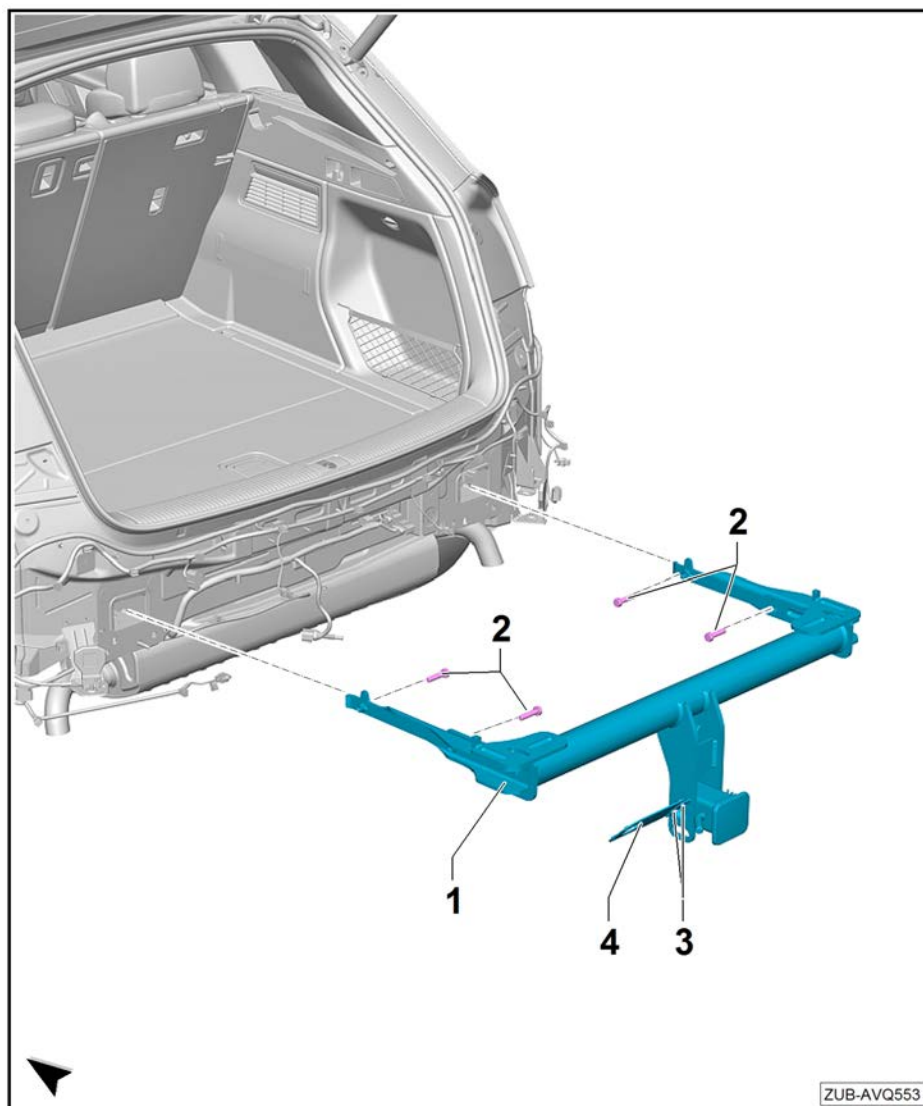

5.2 Luggage compartment electrical system

- 1 - Bracket for trailer detector control unit -J345-
 - Additional required parts ⇒ [Page 8](#)
- 2 - Fitting trailer detector control unit -J345-
- 3 - Earth stud on left in luggage compartment
 - 9 Nm
- 4 - Onboard supply wiring harness
- 5 - Retrofit electrical socket wiring harness
- 6 - Fuse holder in rear left luggage compartment
- 7 - Convenience system central control unit -J393-
 - Underneath the fuse holder

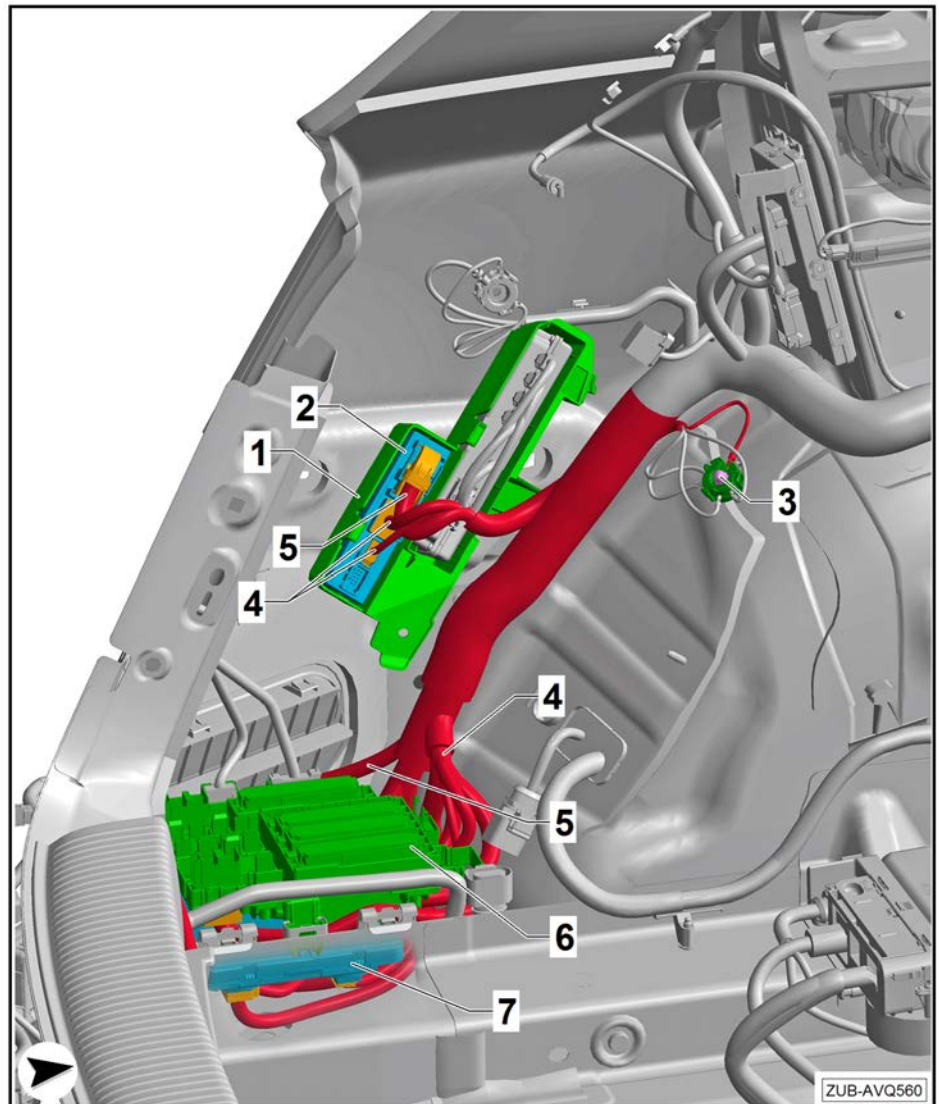



6 Preparations

Required special tools, testing instruments, measuring instruments and auxiliary devices

- ◆ Torque wrench -V.A.G 1410-

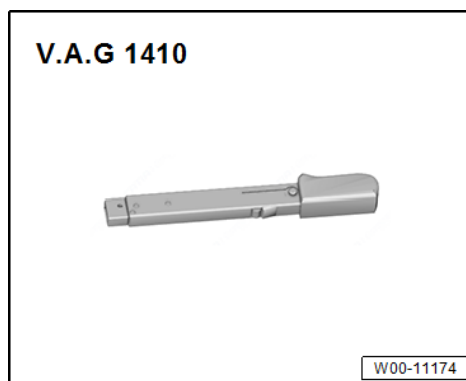

- ◆ Torque wrench -V.A.G 1332-

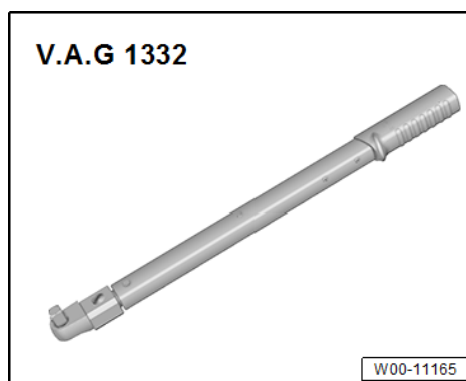

- ◆ Removal lever -80 - 200-

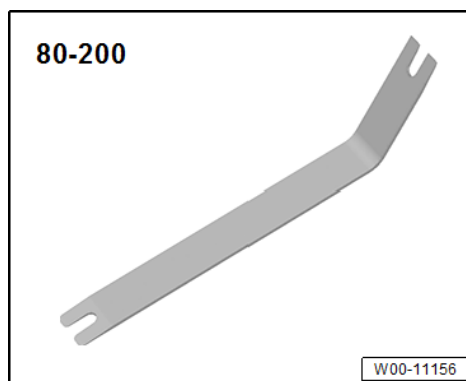

- ◆ Wedge -3409-

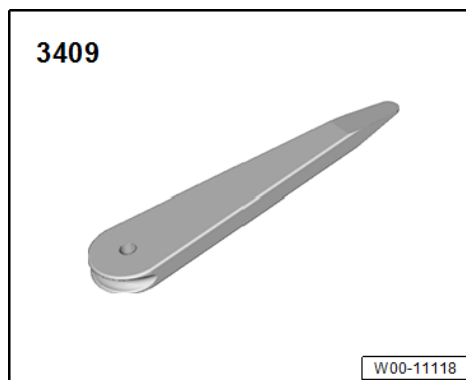



6.1 Disconnecting the battery

- Disconnecting the battery ⇒ Electrical system; Rep. gr. 27; Battery; Disconnecting and connecting the battery

WARNING

- ◆ ***Always make sure that the vehicle's electrical system is protected by disconnecting the battery before performing work on the electrical system.***
- ◆ ***Only unscrew the battery negative terminal (-) of the battery.***
- ◆ ***The battery positive terminal (+) of the battery must only be unscrewed once the battery has been removed from the vehicle.***

6.2 Removing the following equipment

- Remove the luggage compartment floor mat - Equipment variant ⇒ General body repairs, Interior; Rep. gr. 70; Luggage compartment trims; Removing and installing the luggage compartment floor mat
- Remove the subwoofer -R211- – equipment variant ⇒ Communication; Rep. gr. 91; Sound system; Removing and installing the subwoofer -R211-
- Remove the front luggage compartment floor – Equipment variant ⇒ General body repairs, Interior; Rep. gr. 70; Luggage compartment trims; Removing and installing the front luggage compartment floor
- Remove the rear lid lock trim ⇒ General body repairs, interior; Rep. gr. 70; Luggage compartment trim; Removing and installing the rear lid lock trim
- Remove the fastening rings ⇒ General body repairs, Interior; Rep. gr. 70; Luggage compartment trims; Removing and installing the fastening rings
- Remove the rear shelf ⇒ General body repairs, interior; Rep. gr. 70; Interior trims; Removing and installing the rear shelf
- Remove the left and right luggage compartment lights -W3- ⇒ Electrical system; Rep. gr. 96; Lights; Removing and installing the left and right luggage compartment lights -W3-
- Remove the luggage compartment side trim ⇒ General body repairs, Interior; Rep. gr. 70; Luggage compartment trims; Removing and installing the luggage compartment side trim
- Assembly overview of the bumper cover ⇒ General body repairs, Exterior; Rep. gr. 63; Rear bumper; Assembly overview of the bumper cover
- Remove rear bumper cover ⇒ General body repairs, exterior; Rep. gr. 63; Rear bumper; Removing and installing the bumper



- Assembly overview of the impact bar ⇒ General body repairs, Exterior; Rep. gr. 63; Rear bumper; Assembly overview of the impact bar
- Remove the impact bar ⇒ General body repairs, Exterior; Rep. gr. 63; Rear bumper; Removing and installing the impact bar
- Remove the heat shield from underneath the impact bar.

According to equipment, also remove:

- Premium-sound amplifier
- Bracket for premium-sound amplifier



7 Installing the towing bracket

7.1 Fitting the towing bracket

Special tools and workshop equipment required

- ◆ Hot air blower
- ◆ Cartridge gun for bodywork sealant

Preparatory work

⚠ Caution

The body fold and threaded holes must be sealed using a suitable bodywork sealant to prevent any moisture from entering them.

Seal the holes of the detached damper

📄 Note

The area of the bonding surfaces on the rear of the vehicle must be cleaned. Treat bare metal body parts with anti-rust paint.

- Stick the adhesive spots -A- onto the holes and heat using a hot air blower.

📄 Note

Applying heat to the adhesive spots increases their elasticity and bonds them with the body.

Seal the longitudinal member body fold

📄 Note

The area of the bonding surfaces around the body folds must be cleaned. Treat bare metal body parts with anti-rust paint.

- Seal the body fold of longitudinal member -B- on the right, left and in the upper area using bodywork sealant.

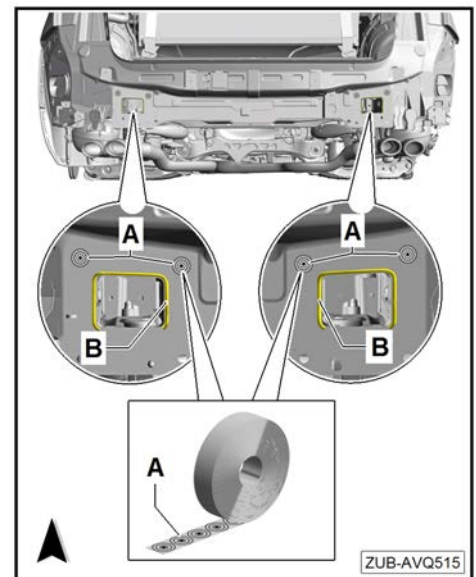

7.2 Installing the towing bracket

- Position the towing bracket on the ends of the frame with the help of a second technician.

⚠ Caution

Make sure that the towing bracket with cross member is handled and transported correctly. Only transport the towing bracket on the cross member -1-.



- Remove adhesive spots in the luggage compartment that are covering the mounting holes on the longitudinal member.
- Insert bolts -A to D- on the left and right on the inside for securing the towing bracket and tighten the bolts by hand.
- Align the towing bracket and tighten bolts -A, B, C and D in that order- with the torque specified for towing brackets with cross members.



WARNING

Securing bolts must only be used once.

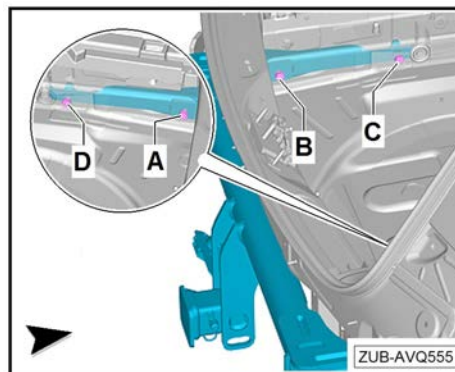

7.3 Connector panel assembly

- Fit connector panel -1- for the trailer socket to the towing bracket.
- Tighten bolts -2- to the required torque ⇒ [Page 10](#)

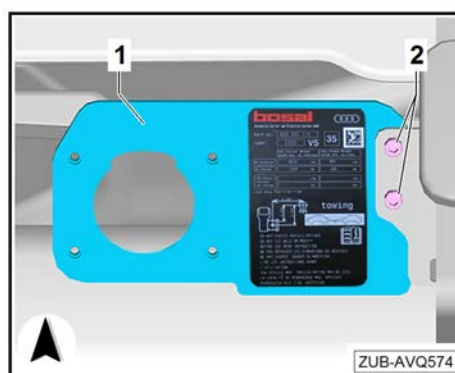



8 Electrical connection

8.1 Fitting the socket with retrofit wiring harness to the connector panel

- Route the socket retrofit wiring harness with 7-pin contact insert through the opening in the connector panel.
- Insert the contact insert of the socket retrofit wiring harness into the socket housing from the rear and position the socket housing in the connector panel.
- Insert the bolts for securing the socket from the front and tighten the bolts. Tightening torque ⇒ [Page 8](#)

8.2 Installing the bracket for the trailer detector control unit -J345-

Applies to vehicles with 1D0+KA0/KA2 or 1D8+KA0/KA2

Note

Order bracket 80A.907.297 ⇒ *Electronic parts catalogue*

- Insert bracket -1- for the trailer detector control unit -J345- in -the direction of arrow A-.
- Push the bracket -1- for the trailer detector control unit -J345- downwards in -the direction of arrow B- and secure with bolt -3-.
- Insert the trailer detector control unit -J345- into the assembled control unit bracket and snap in place.

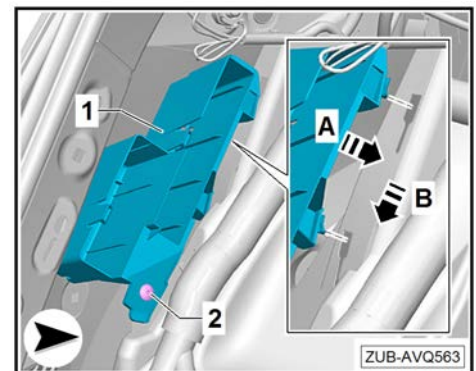

8.3 Routing and connecting the socket retrofit wiring harness

According to equipment

- Turn bolts -arrows- until they are slightly loose and press the heat shield -1- towards the towing bracket.

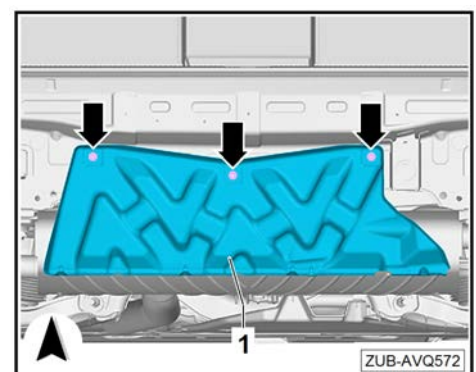



- Remove sealing cap -1- from the bottom opening in the body -in the direction of the arrow-.

i Note

The cap -1- is no longer required once the towing bracket has been mounted.

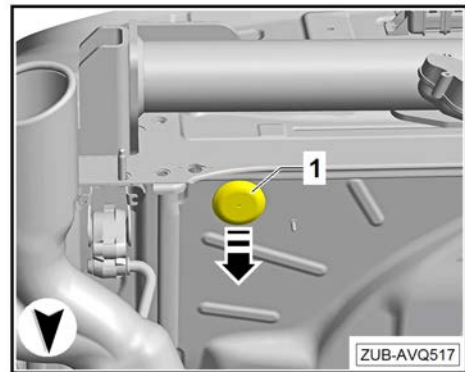

- Pull the socket retrofit wiring harness connector -1- through the opening in the body and insert the sealing plug -3-.
- Route the socket retrofit wiring harness -2- behind the convenience system central control unit -J393- towards the trailer detector control unit -J345-.
- Connect electrical connector -1- of the socket retrofit wiring harness to the trailer detector control unit -J345-.

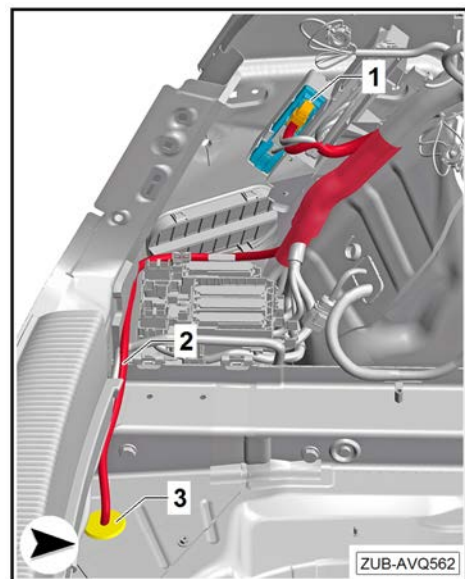

- Secure the free earth wires of the retrofit wiring harness-2- to the earth point .
- Connect electrical connectors -4- and -5- of the vehicle's on-board supply wiring harness to the trailer detector control unit -J345- -1-.

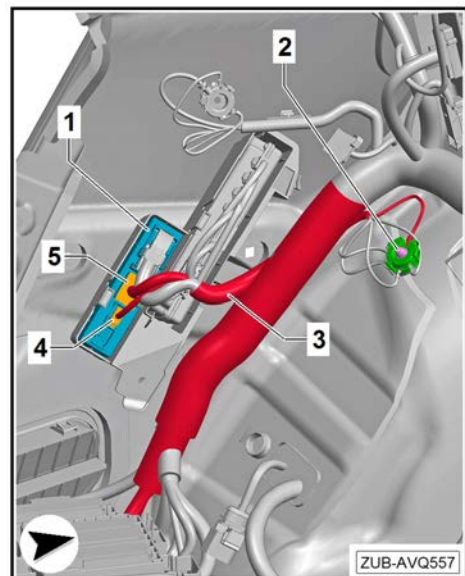



- Press heat shield -1- towards the cross panel, insert bolts -arrows- and tighten to a torque of 2.5 Nm.

Note

Make sure the retrofit wiring harness moves freely.

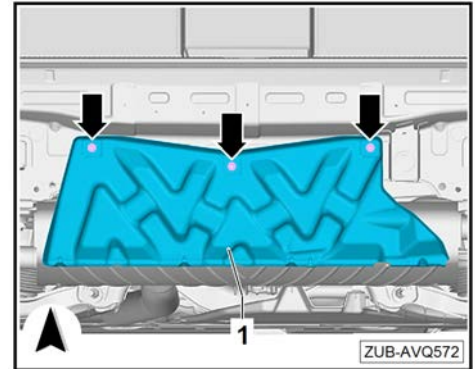

8.4 Connecting the supply line for the brake booster

WARNING

There are two variants for the position of the brake booster supply line.

Variant 1: Up to VIN no. WA1BNAFY8J2000552, the on-board supply wire for the brake booster is located under the convenience system central control unit -J393-.

Variant 2: From VIN no. WA1BNAFY8J2000552, the on-board supply wire for the brake booster is integrated in the main wiring harness above the fuse holder.

8.4.1 Workflow for variant 1

- Loosen fastener -2- and pull fuse holder -1- upwards slightly.

Detach fuse holder -1- from the tabs -3- and remove it upwards -in the direction of the arrow-.

Place the fuse holder -1- to one side.

Note

The electrical wires remain connected.

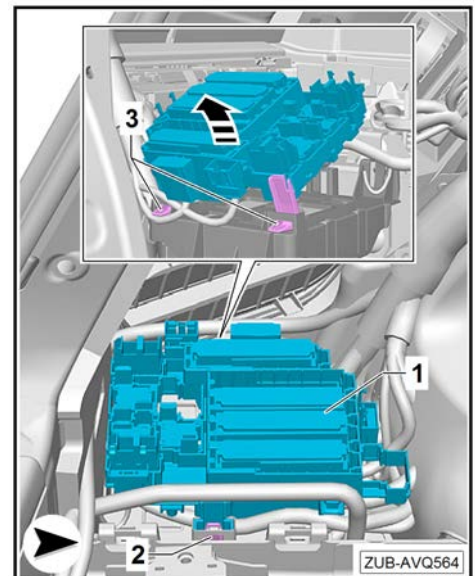



- Release the convenience system central control unit -J393- holder
- Loosen the rear securing nuts -1-.
- Loosen the bracket -3- on the fasteners -2- pull upwards with the convenience system central control unit -J393- -arrows-.

i Note

The electrical wires remain connected.

- Pull the onboard supply wire for the brake booster -1- upwards towards the main wiring harness and secure in place with a cable tie.
- Reinstall the bracket for the convenience system central control unit -J393- and fuse holder.
- Connect the onboard supply wire for the brake booster on the main wiring harness -1- to the wire for the brake booster of the socket retrofit wiring harness -2- -in the direction of the arrow-.

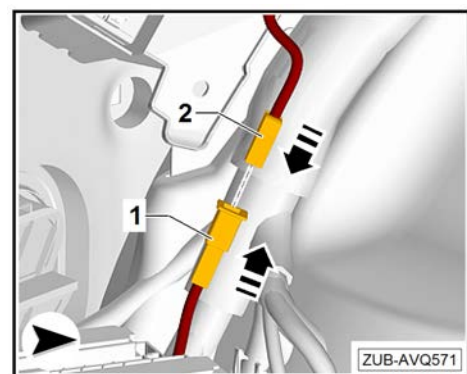
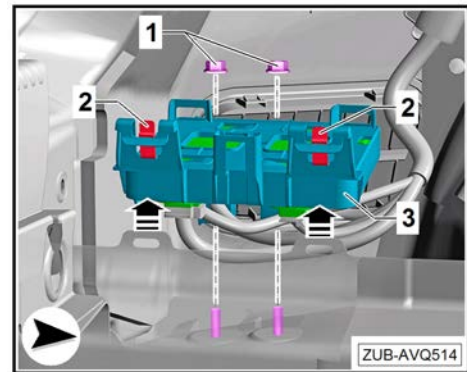

8.4.2 Workflow for variant 2

- The onboard supply wire for the brake booster -1- is secured to the main wiring harness ex works.
- Connect the onboard supply wire for the brake booster -1- to the wire for the brake booster of the socket retrofit wiring harness -2- -in the direction of the arrow-.

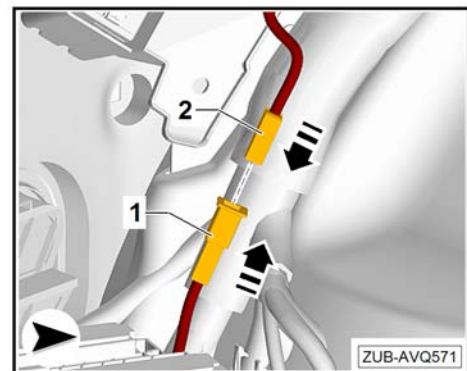



9 Concluding operations

9.1 Reassembling the vehicle

To install the components, follow the removal steps in reverse order. Observe the "Notes on installation" for the relevant components and the corresponding tightening torques.

On vehicles with lane change assist, this must be recalibrated.

WARNING

The following information must be observed when working with the lane change assist (Audi side assist):

- ◆ *If the rear bumper cover is removed and then reinstalled, or if any modifications are made to the rear bumper cover, the lane change assist system (Audi side assist) must be recalibrated ⇒ Electrical system; Rep. gr. 96; Risk of accident due to malfunction!*

9.2 Connecting the battery

- Connect the battery ⇒ Electrical system; Rep. gr. 27; Battery; Disconnecting and connecting the battery

Note

After reconnecting the power supply, the ESP warning light can only extinguish after a few metres have been driven.

9.3 Adapting the trailer detector control unit -J345- coding

Coding is adjusted using the ⇒ Vehicle diagnostic tester. This must be connected online.

WARNING

Before you start the activation process, go into the self-diagnosis function and check that it is possible to contact the DA69 (towing bracket control unit); this ensures that the CAN bus is connected.

Enter the "clear error" (Fehler löschen) command for the DA69 in the self-diagnosis function; by doing so, you can identify whether all power supplies and the earth are present; if the result is positive, you can continue; if the result is negative, check all power supplies as well as the fuse and contacts!

If this is not done, you will receive result code FFP0707E.

9.4 Commissioning and functional check

- Check that the trailer socket functions correctly using a suitable trailer socket tester or a trailer.



Pin assignment at the trailer socket

- 1 - Terminal LH (left-hand brake light/turn signal)
- 2 - Terminal 31 (earth)
- 3 - Electrical brake (brake booster)
- 4 - Terminal RH (right-hand brake light/turn signal)
- 5 - Terminal 30 (battery +)

Note

Constant current 12 V, max. current 15 A.

- 6 - Terminal 58 (tail lights)
- 7 - Terminal RVL (reversing light)

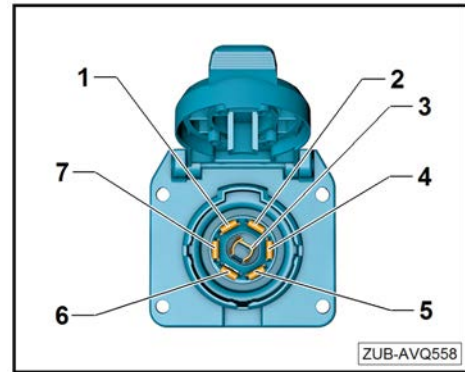

9.5 Adjusting the cooling system

As towing mode puts greater demands on the engine cooling system, the cooling system is upgraded – where technically possible – when the towing bracket is installed in the factory.

The cooling system does not need to be upgraded if it is possible to guarantee that the engine is only ever exposed to the following conditions:

- ◆ The permissible gross combination weight is underrun
- ◆ No high ambient temperatures
- ◆ No long, steep inclines
- ◆ No high altitude journeys

In any case, the coolant temperature display must be carefully monitored. If the display moves into the hot area, the speed must be reduced immediately. A cool-down time must also be allowed for if necessary. This involves the allowing the engine to idle for approx. 2 minutes to prevent a build-up of heat.