

## Installation instructions

**AUDI Q7 2015 ▶**

**AUDI Q7 e-tron 2016 ▶**

**AUDI Q7 (PU) 2020 ▶**

**Towing bracket with electrics set (NAR)**

**for package number 4M0.092.115.\***

**Audi Genuine Accessories**

Edition 01



## Contents

<b>1</b>	<b>General notes</b> .....	<b>1</b>
<b>2</b>	<b>Safety precautions for vehicles with high-voltage components</b> .....	<b>2</b>
2.1	Safety precautions when working on a high-voltage system .....	2
2.2	Safety precautions when working in the vicinity of high-voltage components .....	2
2.3	Danger classification of the high-voltage system and qualifications required .....	3
<b>3</b>	<b>Safety instructions for pyrotechnical, electrical and mechanical components of the restraint system</b> .....	<b>4</b>
3.1	General safety instructions .....	4
3.2	Storing, transporting and disposing of airbag, belt tensioner and battery disconnecter units (pyrotechnic components) .....	5
<b>4</b>	<b>Safety notes on the towing bracket – Fitting and operation</b> .....	<b>6</b>
4.1	Notes on the towing vehicle .....	6
4.2	Notes on the towing bracket .....	6
4.3	Sensitivity to side winds: safety instructions .....	8
<b>5</b>	<b>Overview of components</b> .....	<b>9</b>
5.1	Overview of mechanical components .....	9
5.2	Additional components required. Applies to the Q7 before product upgrade. ....	9
5.3	Overview of mechanical components .....	10
5.4	Overview of electrical system components .....	11
5.5	Additional required parts .....	11
<b>6</b>	<b>Assembly overview and tightening torques</b> .....	<b>12</b>
6.1	Towing bracket with cross member .....	12
6.2	Luggage compartment electrical system .....	13
<b>7</b>	<b>Preparations</b> .....	<b>14</b>
7.1	Disconnecting the battery .....	15
7.2	Removing the rear bumper cover .....	15
7.3	Removing the rear impact bar .....	16
7.4	Removing the rear impact bar, Q7 e-tron .....	17
7.5	Removing the luggage compartment floor cover .....	17
7.6	Removing the rear cross panel trim .....	17
7.7	Remove the left-hand luggage compartment side trim .....	17
7.8	Removing the retaining plate with the digital sound package -J525- control unit .....	18
7.9	Detaching the relay and fuse holder -F- on the left-hand side of the luggage compartment .....	18
7.10	Release the convenience system central control unit -J393- holder .....	19
<b>8</b>	<b>Installing the towing bracket</b> .....	<b>20</b>
8.1	Fitting the towing bracket .....	20
8.2	Installing the socket .....	21



<b>9</b>	<b>Electrical connection</b> .....	<b>23</b>
9.1	Installing the control unit bracket .....	23
9.2	Fitting trailer detector control unit -J345- .....	23
9.3	Routing the retrofit wiring harness .....	24
9.3.1	"Socket/swing motor" retrofit wiring harness routing .....	26
9.3.2	Routing of onboard supply retrofit wiring harness .....	27
9.3.3	Routing the onboard supply retrofit wiring harness for Q7 e-tron .....	27
9.4	Connecting the onboard supply retrofit wiring harness .....	28
9.4.1	Integrating the CAN bus .....	28
9.4.2	Connecting the brake light signal/terminal 15 .....	30
9.5	Installing the holder and convenience system central control unit -J393- .....	32
9.6	Establishing a power supply .....	33
9.7	Connecting the fuses for the power supply .....	35
9.8	Connecting the battery .....	36
9.9	Adapting the trailer detector control unit -J345- coding .....	36
9.10	Functional check on the socket .....	37
<b>10</b>	<b>Concluding operations</b> .....	<b>38</b>
10.1	Creating the opening required for the ball coupling .....	38
10.2	Creating the opening required for the ball coupling .....	39
10.3	Diffuser adjustment with the bracket for rear lid power opening control unit -J938- when a score line is available .....	40
10.4	Diffuser adjustment with bracket for rear lid power opening control unit -J938- without a score line .....	41
10.5	Reassembling the vehicle .....	42
10.6	Finishing the assembly work .....	43
10.7	Adjusting the cooling system .....	43





# 1 General notes

Please read and take note of these WARNING, Caution and Note descriptions before carrying out maintenance or repair work.



## **WARNING**

***Text with this symbol contains information concerning your safety and indicates potential accident and injury risks.***



## **Caution**

***Text with this symbol indicates the risk of damage to your vehicle.***



## **Note**

*Text with this symbol contains additional information.*



## **Caution**

***Towing mode places increased demands on the cooling system.***

- ◆ ***The cooling system ⇒ Page 43 must be adapted to the vehicle operating conditions .***

**Special tools are required for assembly. Improper installation can cause damage to the vehicle or the add-on parts.**

**AUDI AG shall not accept responsibility in the event of failure to comply with these installation instructions.**



## **2 Safety precautions for vehicles with high-voltage components**

### **2.1 Safety precautions when working on a high-voltage system**

#### **Danger to life due to high voltage**

The high-voltage system carries a high voltage. Death or severe bodily injuries due to electric shock.

- People with electronic/medical lifesaving and health-promoting devices in or on the body are not permitted to carry out work on a high-voltage system. Lifesaving and health-promoting devices include, for example, internal analgesic pumps, implanted defibrillators, pacemakers, insulin pumps and hearing aids.
- Have a high-voltage system de-energised by a correspondingly qualified person.

#### **Risk of injury due to unexpected engine start**

With regard to electric and hybrid vehicles, it is difficult to detect an activated vehicle traction standby system. It is possible for body parts to be pinched and pulled in.

- Switch off the ignition.
- Place the ignition key outside of the vehicle interior.

#### **Risk of damage due to high-voltage lines**

Incorrect handling can damage the insulation of high-voltage lines or high-voltage connectors.

- Never lean on high-voltage lines or high-voltage connectors.
- Never rest a tool on high-voltage lines or high-voltage connectors.
- Never bend or kink high-voltage lines by a significant amount.
- When connecting high-voltage connectors, observe the coding.

#### **Risk of injury due to an activated independent air-conditioning system**

With regard to electric and hybrid vehicles with an activated independent air-conditioning system, this system can inadvertently switch itself on. It is possible for body parts to be pinched and pulled in by self-starting radiator fans.

- Deactivate the independent air-conditioning system.

### **2.2 Safety precautions when working in the vicinity of high-voltage components**

#### **Danger to life due to high voltage**

The high-voltage system carries a high voltage. Death or serious bodily injuries due to electric shock in the case of high-voltage components and high-voltage lines being damaged.

- Carry out a visual inspection of the high-voltage components and high-voltage lines.
- Never use cutting, deforming or sharp-edged tools.



- Never weld or braze, carry out thermal bonding or use hot air.

## 2.3 Danger classification of the high-voltage system and qualifications required

The various tasks to be completed in the vicinity of or directly on high-voltage components require different qualifications ⇒ basic information regarding high-voltage vehicles; Rep. gr. 00; qualification of internal/external personnel.



## 3 Safety instructions for pyrotechnical, electrical and mechanical components of the restraint system

### 3.1 General safety instructions

Pyrotechnical components comprise:

- ◆ Airbag units
- ◆ Belt tensioners
- ◆ Belt force limiters
- ◆ Battery disconnecting elements

#### General

- ◆ Testing, installation and maintenance tasks must only be carried out by trained personnel.
- ◆ There are no replacement intervals for airbag units.
- ◆ Do not check using circuit tester, voltmeter, or ohmmeter under any circumstances.
- ◆ Pyrotechnic components may only be checked when installed and using ⇒ vehicle diagnostic testers that have been approved by the manufacturer.
- ◆ When working on pyrotechnic components and the airbag control unit -J234-, the battery earth wire must be disconnected when the IGNITION is SWITCHED ON. The battery negative terminal must subsequently be covered.
- ◆ You must wait ten seconds after the battery -A - has been disconnected.
- ◆ The battery -A - must be connected when the IGNITION is SWITCHED ON. There must not be anybody inside the vehicle during this process. Exception: vehicles with battery -A- located inside the vehicle. Do not sit within the airbag and seat belt deployment range.
- ◆ Observe the appropriate steps after connecting the battery -A - ⇒ [Page 15](#).
- ◆ Before performing any work on pyrotechnic components in the restraint system, e.g. before disconnecting the electrical connector, the mechanic carrying out the task must discharge any static electricity. Electrostatic discharging can be performed by touching earthed metal parts, e.g. by briefly touching the door striker plate.
- ◆ Wash hands after touching ignited pyrotechnical components of the restraint system.
- ◆ Pyrotechnical components must neither be opened nor repaired. New parts must always be used (risk of injury).
- ◆ Pyrotechnic components that have fallen onto a hard surface or that show any sign of damage must not be installed.





- ◆ Pyrotechnic components must be installed immediately after they are removed from the transport container.
- ◆ If work is interrupted, the pyrotechnic component must be returned to the transport container.
- ◆ Pyrotechnic components must not be left unattended.
- ◆ When connecting the pyrotechnic components in the restraint system, only the person performing the work may be inside the vehicle.
- ◆ Pyrotechnic components must not be treated with grease, cleaning agents or similar products.
- ◆ If the fabric becomes contaminated with substances such as oil, grease, paint, colour or solvents, the airbag unit must be replaced.
- ◆ In addition, pyrotechnic components must not be exposed to temperatures above 100°C, even for short periods.

### 3.2 Storing, transporting and disposing of airbag, belt tensioner and battery disconnecter units (pyrotechnic components)

- ◆ Storage is subject to the applicable national legislation.
- ◆ Transportation is subject to national and international laws governing packaging, naming, labelling and accompanying documentation.
- ◆ Pyrotechnic components that have not been ignited must be returned in the original packaging for appropriate recycling in line with the applicable national legislation! Contact your importer if you have any questions.
- ◆ Only pyrotechnic components that have been completely ignited may be disposed of as industrial waste.

 **WARNING**

***This does not apply for belt tensioners that operate according to the Wankel tensioner principle. Tensioners of this kind should be handled in the same way as pyrotechnic components that have not been ignited (e.g. airbags).***

***Background: For belt tensioners that operate according to the Wankel tensioner principle, it is not possible to check whether all ignition stages have completed using workshop tools.***



## 4 Safety notes on the towing bracket – Fitting and operation

### 4.1 Notes on the towing vehicle

Manufacturer:	AUDI AG
Model:	Q7 2015 ►, Q7 e-tron 2016 ►, Q7 (PU) 2020 ►
Offic. Type designation:	4L, 4M

Maximum trailer weight or trailer drawbar load in kg, as specified by the manufacturer for the above-named vehicle model: ⇒ Vehicle registration certificate/Owner's Manual.

### 4.2 Notes on the towing bracket

Technical data	
Westfalia:	305 419
Maximum trailer weight:	3500 kg
Permitted trailer drawbar load:	350 kg

Please see your vehicle documents for your maximum trailer weight.



#### **WARNING**

***Do not exceed the maximum trailer weight and the permitted trailer drawbar load – risk of accident!***

The towing bracket is intended for towing trailers fitted with a tow ball and for operating carriers suitable for mounting to the coupling ball.

Nationally applicable regulations must be adhered to in EU and non-EU countries.

Improper use is prohibited.

Use is only permitted under favourable road conditions and must be adapted to road conditions.

Refer to the vehicle Owner's Manual and observe the possibly increased tyre inflation pressures for vehicles with towing brackets or vehicles towing a trailer.

## Assembly



### **WARNING**

**For safety reasons, the towing bracket must only be fitted by skilled personnel – risk of accident!**

- ◆ **If replacement parts are required, these must only be installed by skilled personnel and to undamaged genuine parts – risk of accident!**
- ◆ **Installation must be in line with AUDI AG/Volkswagen AG guidelines – risk of accident!**
- ◆ **Additional modifications to the towing bracket may be required – risk of accident. Detailed information can be found in the installation instructions.**
- ◆ **Use of the mounting points approved as standard by the vehicle manufacturer is mandatory – risk of accident!**

### Operation



### **WARNING**

**Vehicle handling is affected by the use of towing mode; increased driver awareness is required – risk of accident!**

- ◆ **Read the notes in the “Towing mode” chapter of the ⇒ Owner’s Manual – risk of accident!**
- ◆ **If you are using trailer stabilisers, the coupling ball must be free from grease. Read and observe the notes in the relevant Owner’s Manuals – risk of accident!**

**The diameter of the ball coupling must be checked at regular intervals.**

- ◆ **For safety reasons, use of the towing bracket must be discontinued if the diameter reaches 49 mm at any point. If this situation occurs, contact a qualified workshop – risk of accident!**

**For safety reasons, you are advised to swivel the ball rod inwards when not in use – risk of accident!**

### **Caution**

**The ball coupling must always be kept clean.**

### **Note**

- ◆ *The towing bracket including all assembly parts weighs approx. 26 kg.*
- ◆ *Please note that the kerb weight of your vehicle will increase by this amount once the towing bracket is fitted.*
- ◆ *Please make sure that you do not exceed the gross vehicle weight rating for your vehicle.*



### 4.3 Sensitivity to side winds: safety instructions

 **WARNING**

*The load affects driving and braking behaviour and the vehicle's sensitivity to side winds. Adapt your driving style accordingly – risk of accident!*

*When driving in strong side winds, make sure that you take extra care:*

- ◆ *When moving into and out of the slipstreams of lorries,*
- ◆ *When driving past hedgerows, trees, walls and buildings as well as any other wind barriers,*
- ◆ *When driving over bridges.*



## 5 Overview of components

### 5.1 Overview of mechanical components

Applies to the Q7 before product upgrade.

#### 1 - Electrical connection

- Retrofit wiring harness, "socket"

#### 2 - Towing bracket with cross member including "socket" wiring harness

#### 3 - Bolts

- 8 unit
- M12 x 1.5 x 100

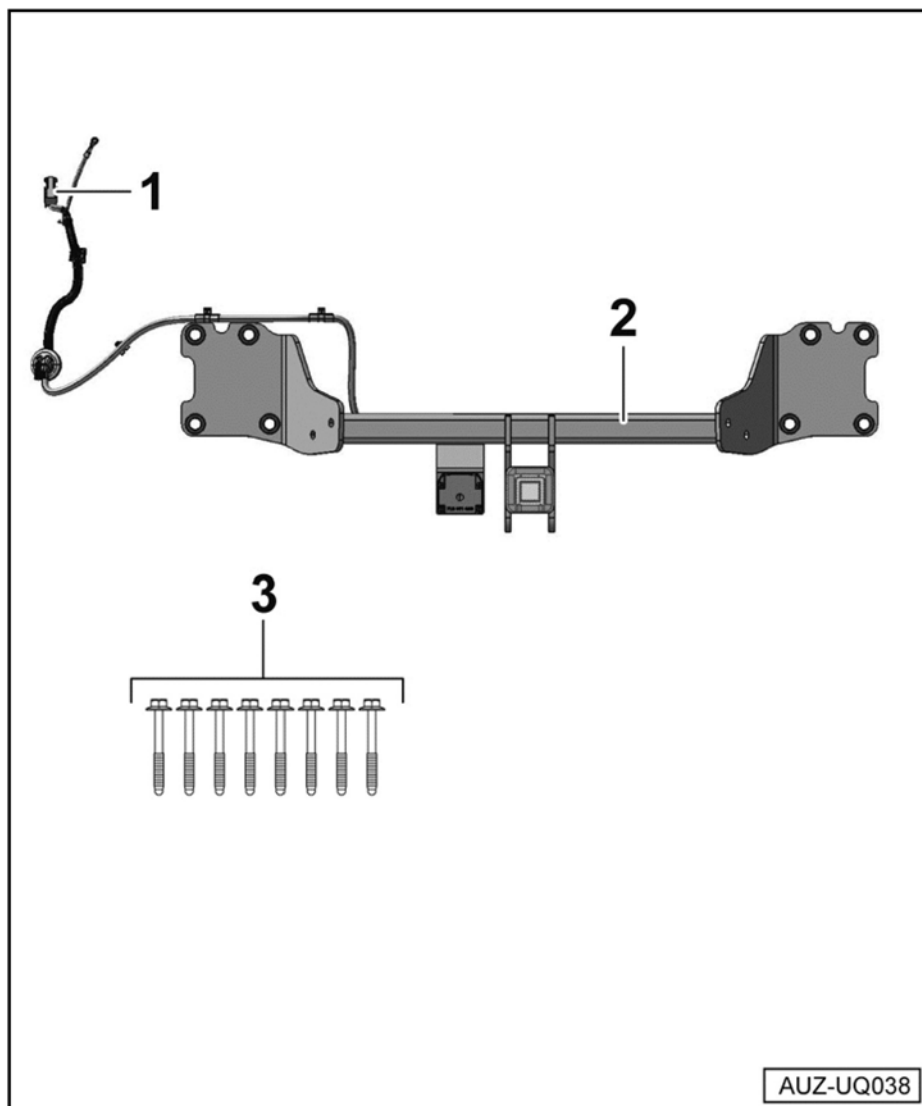

#### Note

The frames contained in package 4M0.092.115.B must not be used.

### 5.2 Additional components required. Applies to the Q7 before product upgrade.

Depending on the drive and equipment variant, the diffuser 4M0.807.434.J or 4M0.807.434.N for basic models including bracket -2- must also be ordered ⇒ Electronic spare parts catalogue "ETKA".

Depending on the drive and equipment variant, the diffuser 4M0.807.434.K for S line and SQ models including bracket -2- must also be ordered ⇒ Electronic spare parts catalogue "ETKA".



## 5.3 Overview of mechanical components

Applies to the Q7 PU.

### 1 - Electrical connection

- ❑ Retrofit wiring harness, "socket"

### 2 - Towing bracket with cross member including "socket" wiring harness

### 3 - Bolts

- ❑ 8 unit
- ❑ M12 x 1.5 x 90

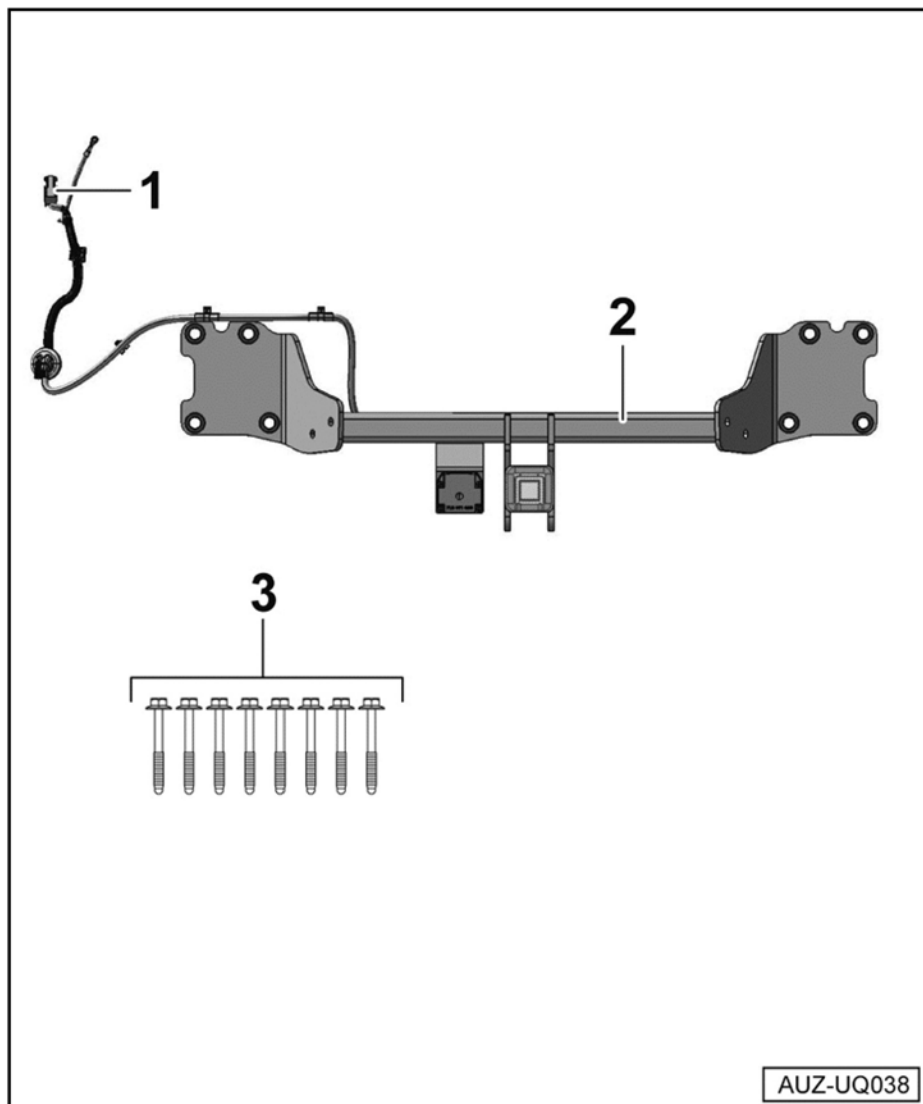

Depending on the bumper or equipment variant, bracket -2- Basic 4M0.807.941.K or bracket -2- S line 4M0.807.941.M is included in the scope of delivery.

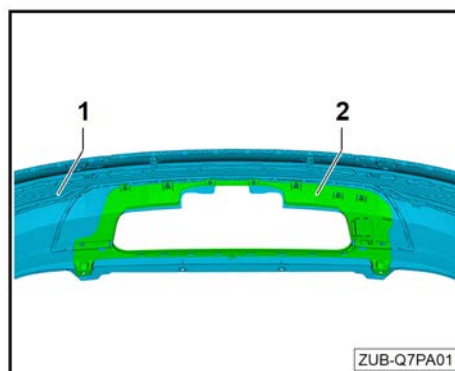



## 5.4 Overview of electrical system components

- 1 - Fitting trailer detector control unit -J345-
- 2 - Socket
  - 7-pin
- 3 - Activation document
- 4 - Safety instructions
- 5 - "Electric brake for trailer not connected" sticker

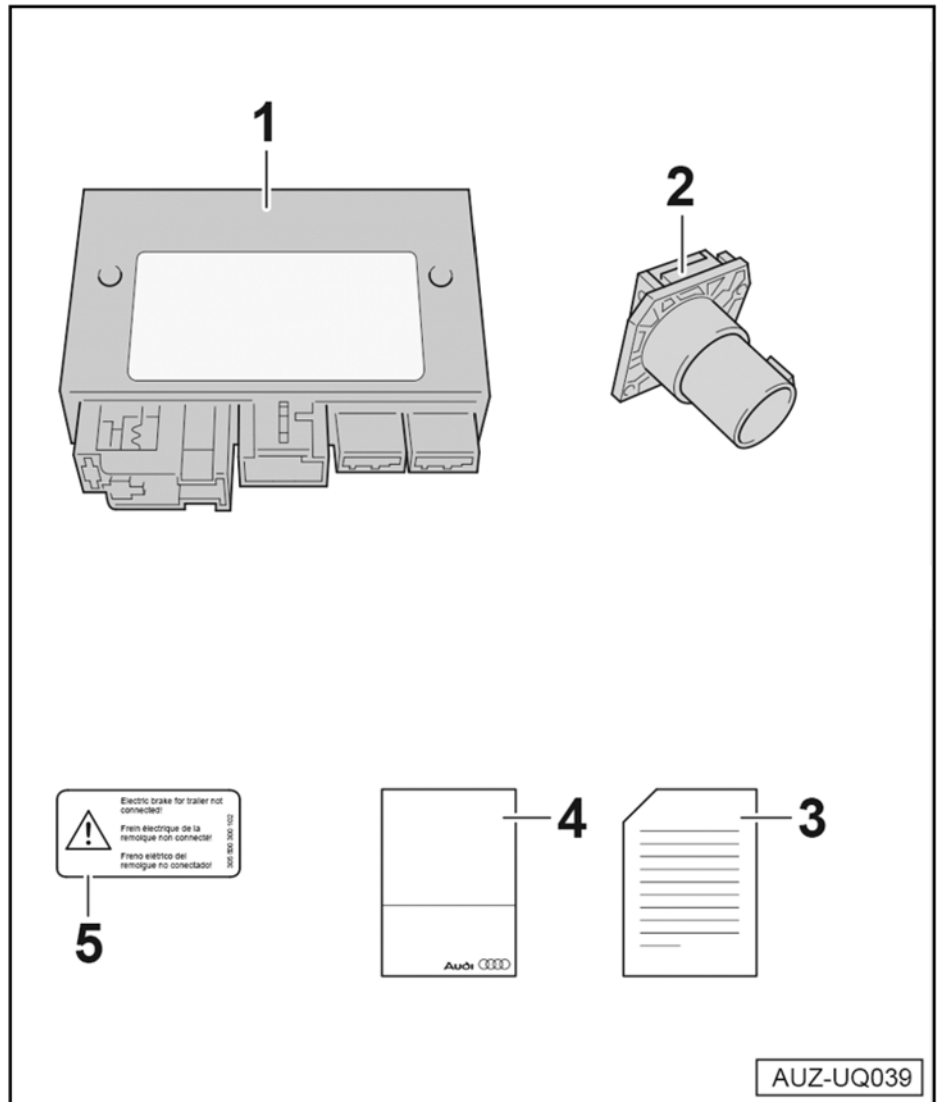

## 5.5 Additional required parts

Only for vehicles without preparation "1D0", if necessary,  
use with:

Holder -1-→ Electronic parts catalogue ETKA

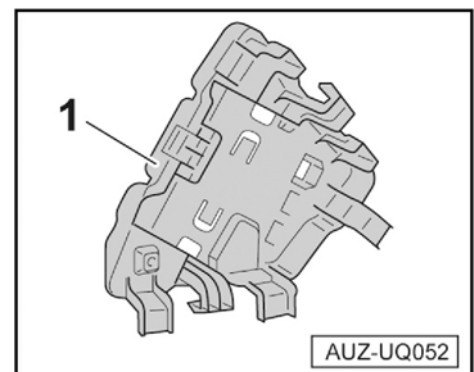



## 6 Assembly overview and tightening torques

### 6.1 Towing bracket with cross member

#### 1 - Towing bracket with cross member

#### 2 - Securing bolt

- ❑ 8 unit
- ❑ M12 x 1.5 x 100  
(applies before PU)
- ❑ Or M12 x 1.5 x 90  
(applies to PU)
- ❑ 110 Nm
- ❑ Replace after removal

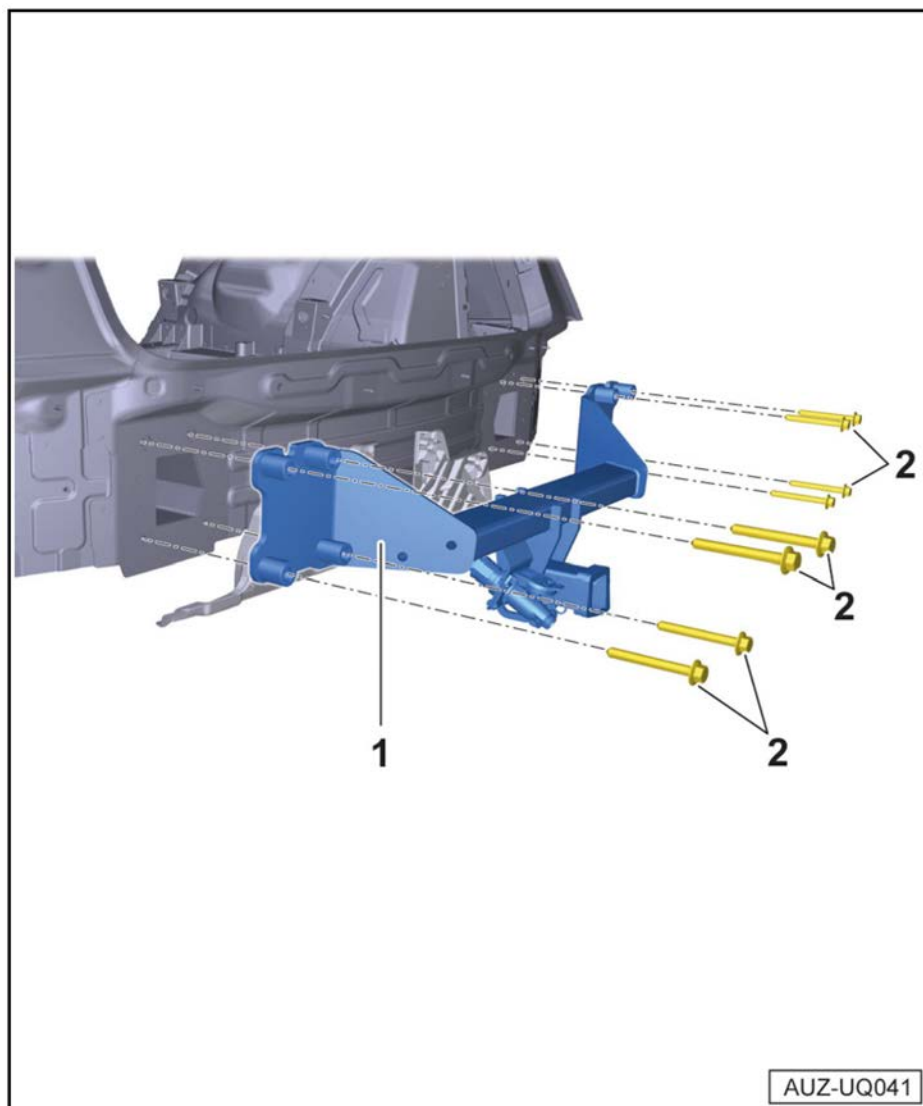





## 6.2 Luggage compartment electrical system

- 1 - Fitting trailer detector control unit -J345-
- 2 - Earth stud on left in luggage compartment  
□ 9 Nm
- 3 - Onboard supply retrofit wiring harness
- 4 - Relay and fuse holder F in the rear left of the luggage compartment
- 5 - Retrofit electrical socket wiring harness
- 6 - Bracket for trailer detector control unit -J345-
- 7 - Foam section

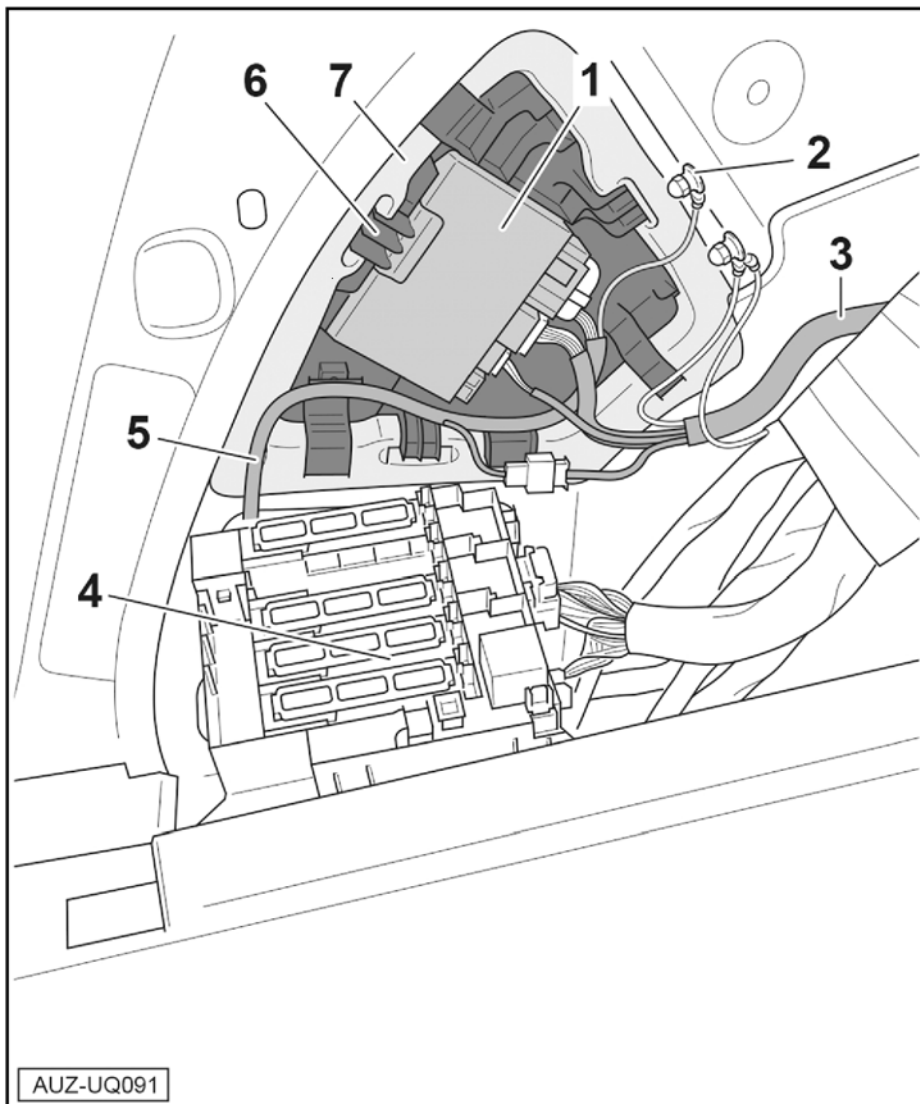

### Only applies to Q7 e-tron

The wiring connection for the power supply to the fuse carrier -6- is located above the rear left-hand wheel housing in the Q7 e-tron.

#### Note

- ◆ Fuse carrier -6- in the Q7 e-tron has a different design, but its functionality is identical.
- ◆ The other components -1–9- are the same and can be seen in the figure ⇒ [Page 13](#).

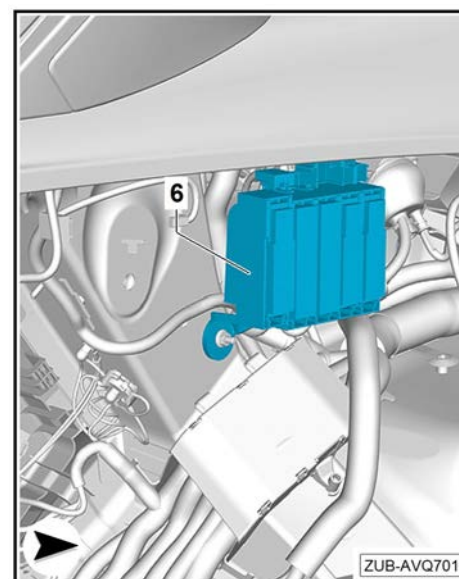

Next steps for all vehicles



## 7 Preparations

### Required special tools, testing instruments, measuring instruments and auxiliary devices

- ◆ Torque wrench -V.A.G 1410-

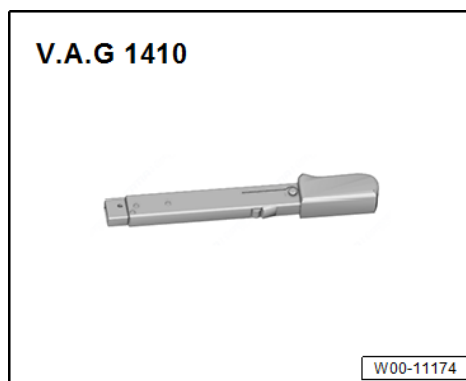

- ◆ Torque wrench -V.A.G 1332-



- ◆ Removal lever -80 - 200-

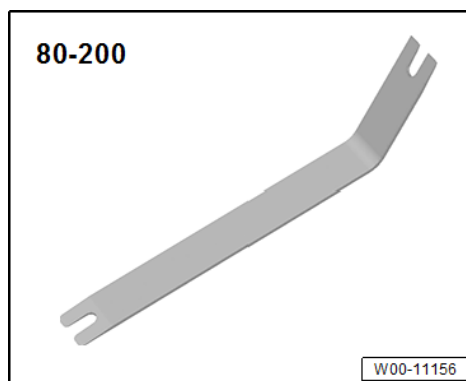

- ◆ Wedge -3409-

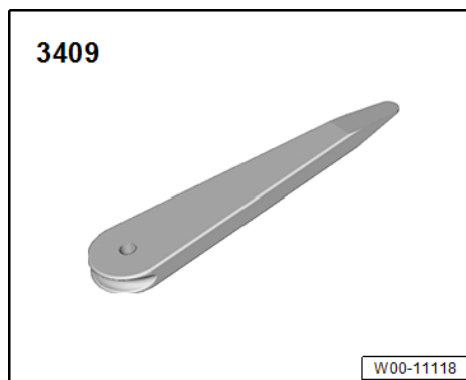

## 7.1 Disconnecting the battery

- Disconnecting the battery ⇒ Electrical system; Rep. gr. 27; Battery; Disconnecting and connecting the battery

### **WARNING**

- ◆ **Always make sure that the vehicle's electrical system is protected by disconnecting the battery before performing work on the electrical system.**
- ◆ **Only unscrew the battery negative terminal (-) of the battery.**
- ◆ **The battery positive terminal (+) of the battery must only be unscrewed once the battery has been removed from the vehicle.**

## 7.2 Removing the rear bumper cover

### 1 - Bumper cover

### 2 - Spoiler

- Clipped into the bumper cover

### 3 - Diffuser

- Clipped into the spoiler
- Make an opening for the ball coupling

### 4 - Screw

- 4 units
- 2.5 Nm

### 5 - Screw

- 4 units
- 2 each for left and right
- 2.5 Nm

### 6 - Screw

- 4 units
- 2 each for left and right
- 2.5 Nm

### 7 - Screw

- 4 units
- 2 each for left and right
- 2.5 Nm

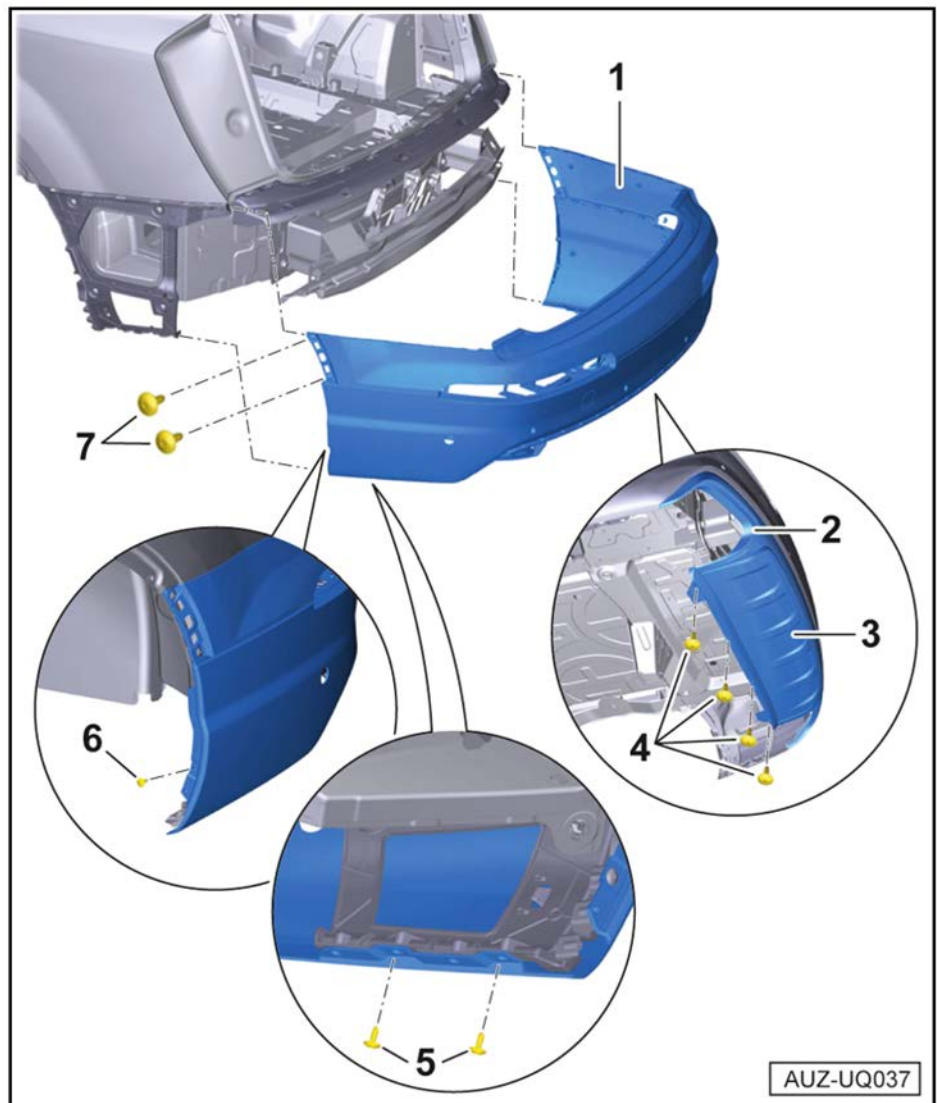



**⚠ WARNING**

**The following information must be observed when working with the lane change assist (Audi side assist):**

- ◆ **If the rear bumper cover is removed and then reinstalled, or if any modifications are made to the rear bumper cover, the lane change assist system (Audi side assist) must be recalibrated ⇒Electrical system; Rep. gr. 96; Risk of accident due to malfunction!**

- Workshop Manual ⇒Rear bumper; Rep. gr. 63; Removing and installing the rear bumper

## 7.3 Removing the rear impact bar

### 1 - Impact bar

- Rear bumper cover removed
- No longer required once the towing bracket is fitted

### 2 - Screw

- 8 unit
- M 12 x 50
- No longer required after removal

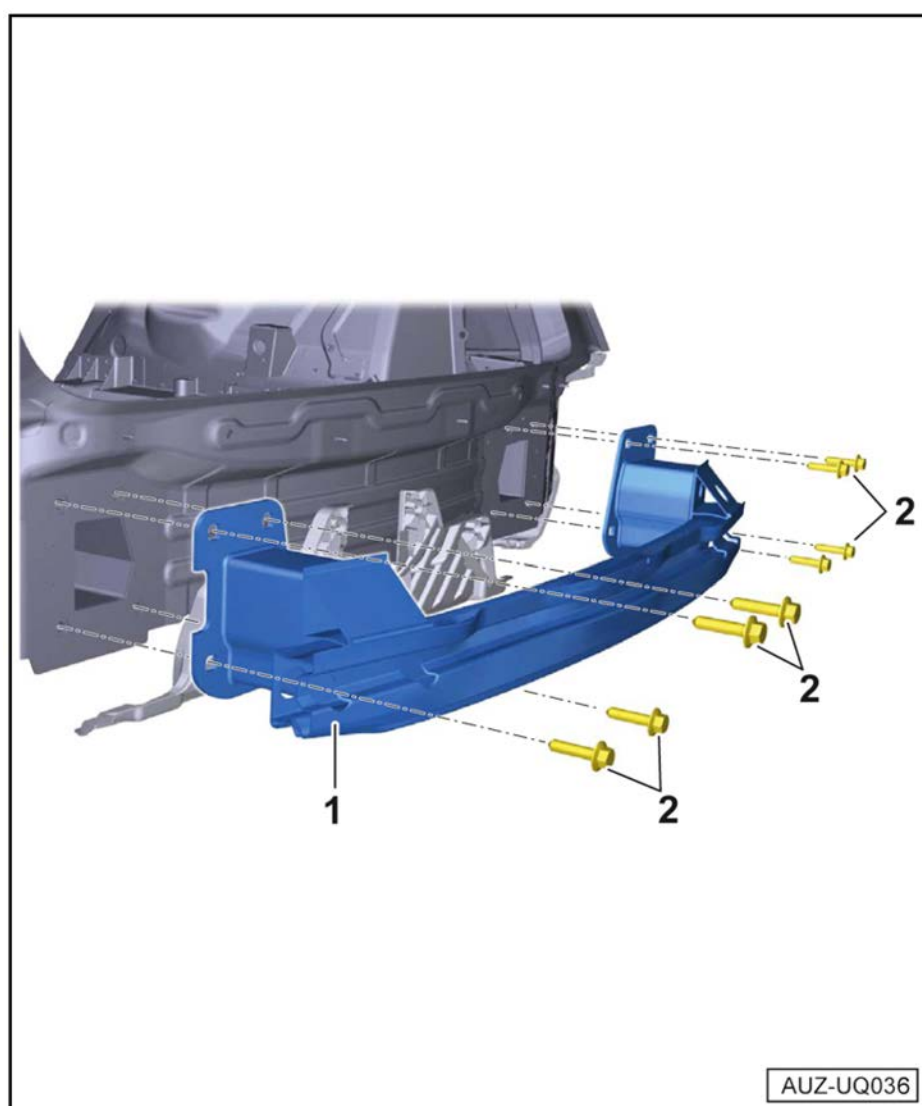

- Workshop Manual ⇒Rear bumper; Rep. gr. 63; Removing and installing the rear bumper

## 7.4 Removing the rear impact bar, Q7 e-tron

### 1 - Impact bar

- Rear bumper cover removed
- No longer required once the towing bracket is fitted

### 2 - Screw

- 8 unit
- M 12 x 50
- No longer required after removal

### 3 - Strut

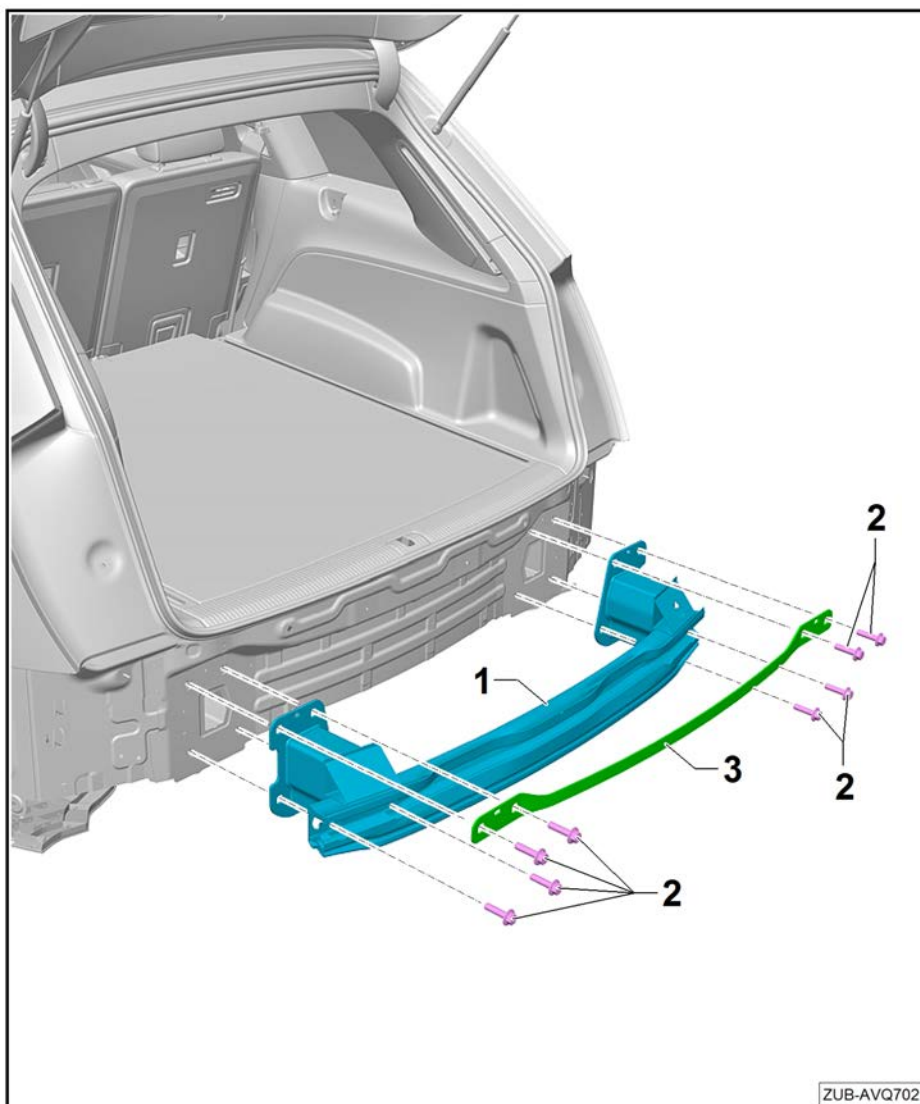

Next steps for all vehicles

## 7.5 Removing the luggage compartment floor cover

- Workshop Manual ⇒ Trims, insulation; Rep. gr. 70; Luggage compartment floor cover

## 7.6 Removing the rear cross panel trim

- Workshop Manual ⇒ Trims, insulation; Rep. gr. 70; Rear cross panel trim

## 7.7 Remove the left-hand luggage compartment side trim .

- Workshop Manual ⇒ Trims, insulation; Rep. gr. 70; Luggage compartment side trim



## 7.8 Removing the retaining plate with the digital sound package -J525- control unit

Only on vehicles with digital sound packages

Only for vehicles without preparation "1D0".

- Workshop Manual ⇒ Communication; Rep. gr. 91; Removing and installing the digital sound package control unit

## 7.9 Detaching the relay and fuse holder -F- on the left-hand side of the luggage compartment

Only for vehicles without preparation "1D0".

- Unlock retaining clips -3- and slightly detach the relay and fuse holder -F- -1-.
- Pull the relay and fuse holder -F- -1- from the guides -2- and put them to one side. The electrical wiring remains connected.

### Notes on installation

Installation is carried out in reverse order. Please note the following points:

- Route electrical wiring in such a way that the original wiring routing is restored.

### Only applies to Q7 e-tron

- Remove the screw -2-.
- Unlock the retaining clips -3- in -the direction of arrow A- and remove the relay and fuse holder -F- -1- in the -direction of arrow B-.
- Put the relay and fuse holder -F- -1- to the side – the electrical wiring remains connected.

### Notes on installation

Installation is carried out in reverse order. Please note the following points:

- Route electrical wiring in such a way that the original wiring routing is restored.

### Next steps for all vehicles

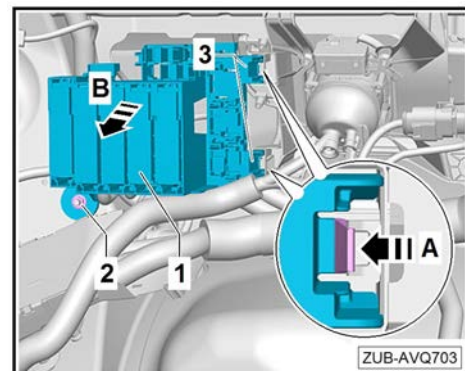
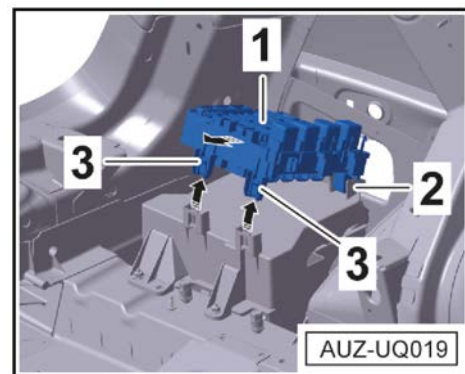



## 7.10 Release the convenience system central control unit -J393- holder

Only for vehicles without preparation "1D0".

- Loosen and remove securing nuts -3-.
  - Remove holder -1- together with the convenience system central control unit -J393- upwards out of guides -2-.
- 
- Put the convenience system central control unit -J393- and holder -1- to one side. The electrical wiring remains connected.

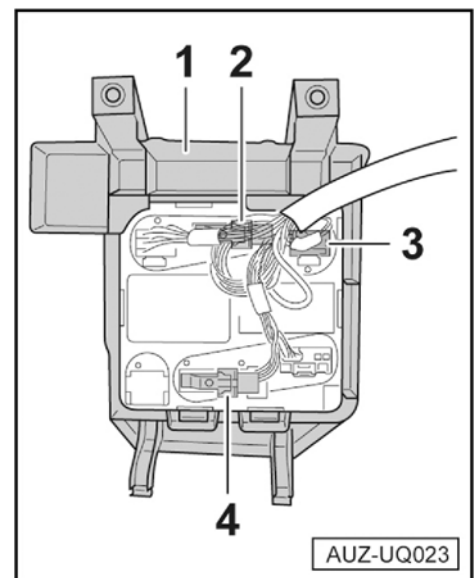
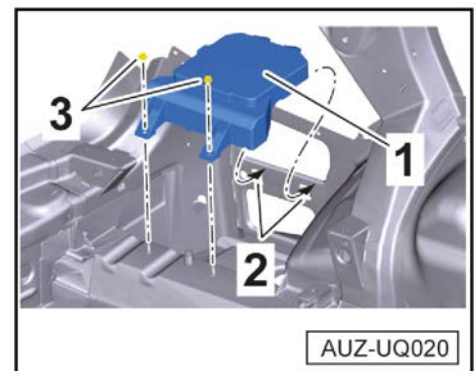



## 8 Installing the towing bracket

### 8.1 Fitting the towing bracket

#### Installing the towing bracket

##### Note

- ◆ When positioning the towing bracket, make sure that the cable -2- is routed over the cross member -1-.
- ◆ The contact surface areas between the towing bracket and vehicle must be cleaned. If necessary, remove drilling chips and treat bare metal body parts with anti-rust paint.
- Position the cross member -1- on the ends of the frame with the help of a second technician.

##### Caution

**Make sure that the towing bracket with cross member is handled and transported correctly. Only transport the towing bracket on cross member -1-. The -2-ball coupling must not be placed under load in the resting position.**

- Insert the left and right bolts -3- for securing the cross member -1- and tighten the bolts by hand.
- Align the towing bracket retaining plate -2- over the bolt holes (centrally) -arrows-.
- Tighten the bolts -3- for towing brackets with cross members  
⇒ Page 12

##### WARNING

**Securing bolts must only be used once.**

- Remove sealing cap -1- from the opening in the body.

##### Note

The cap -1- is no longer required once the towing bracket has been mounted.

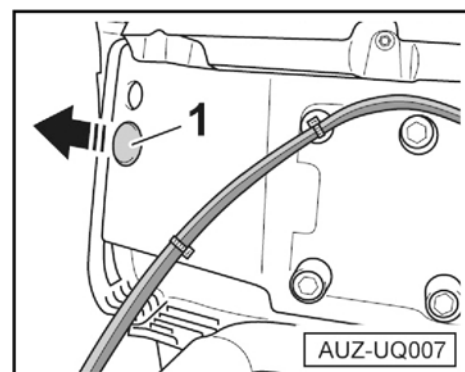
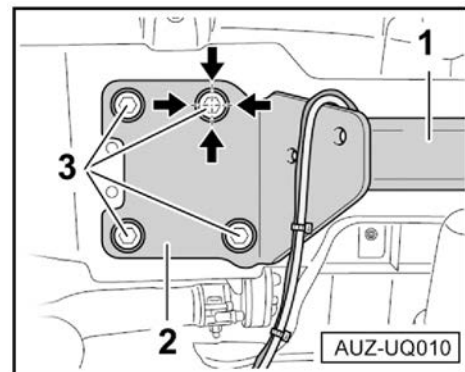
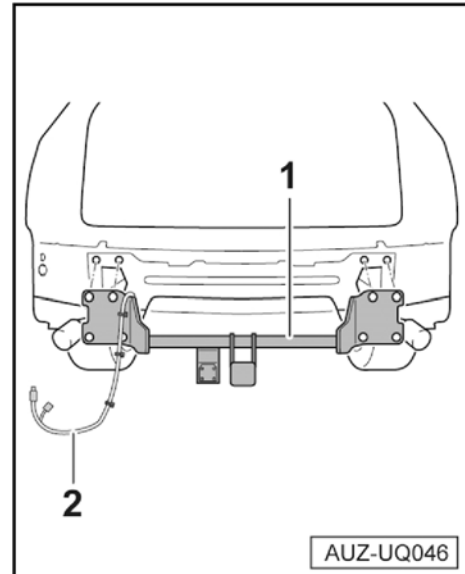





- Guide the "socket/swing motor" retrofit wiring harness through the opening in the body and insert grommet -2-.

**i Note**

*When guiding the wiring through the body, make sure that the electrical connector retaining clip is in the -unlocked- position.*

- Secure the retrofit wiring harness using the retaining clips -1-.

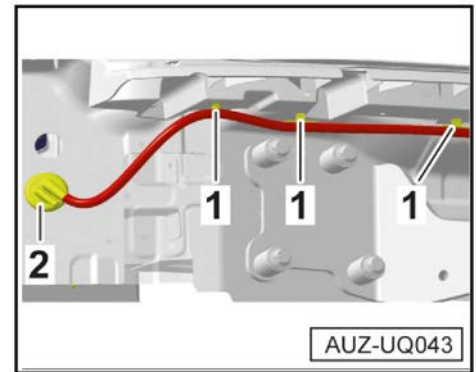

## 8.2 Installing the socket

- Loosen and remove the securing bolts -1- on the cover -2- for the electrical connector.

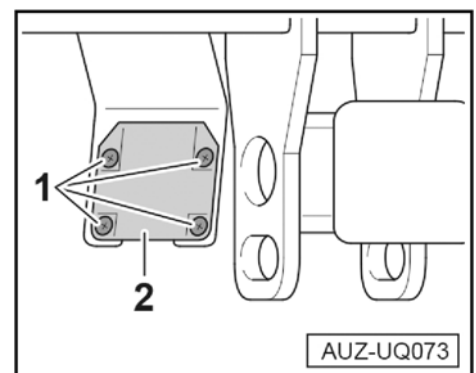

- Gently pull the cover -2- together with the electrical connector -1- from the bracket
- Lift the latch -3- and pull out the locking element -4- for the electrical connector -1- in the direction of the arrow.
- Remove the cover -2- from the electrical connector -1-.

**i Note**

*The cover for the electrical connector -1- is no longer required once the towing bracket has been installed.*

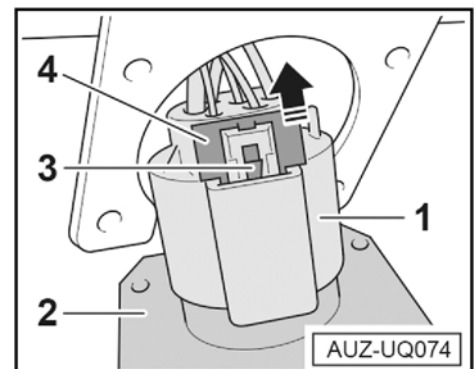

- Connect the trailer socket -2- to the electrical connector -1-.

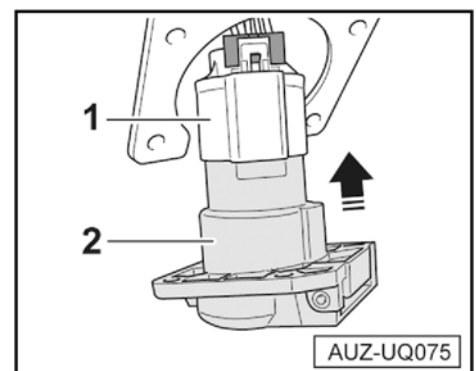



- Press in the locking element -1- for the electrical connector in -the direction of the arrow-.

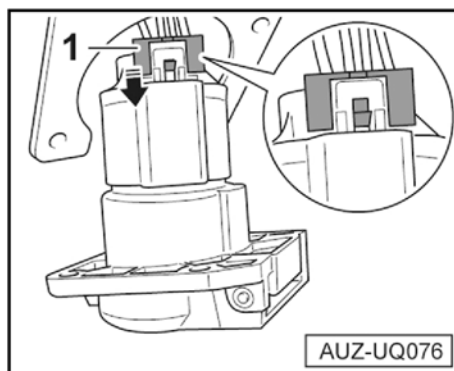

- Insert the trailer socket -2- in the bracket -1-.
- Insert bolts -3- and tighten to a tightening torque of 2 Nm.

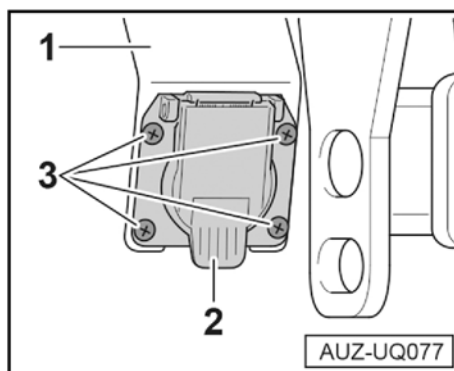



## 9 Electrical connection

### 9.1 Installing the control unit bracket

Only for vehicles without preparation "1D0".

Bracket -2- must also be installed in vehicles without a control unit bracket in the left-hand side of the luggage compartment.

Additional required parts ⇒ [Page 11](#)

- Insert bracket -2- into foam section -1-.

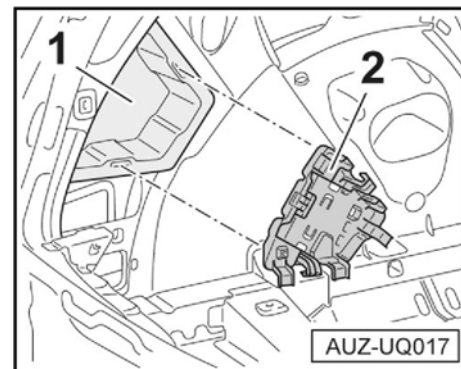

### 9.2 Fitting trailer detector control unit -J345-

Only on vehicles with PR number "1D8" (preparation for towing bracket)

- Connect electrical connectors -2- and -3- of the onboard supply retrofit wiring harness to the trailer detector control unit -J345- -1-

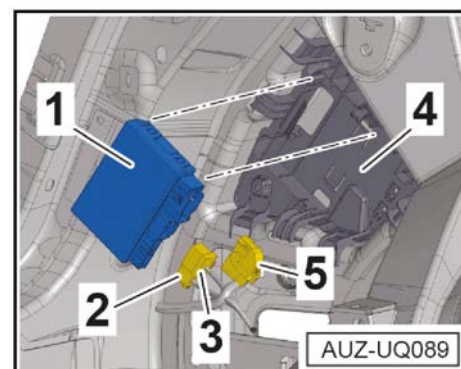

Only for vehicles without preparation "1D0".

- Disconnect the electrical connectors -1, 2 and 3- of the vehicle's onboard supply wiring harness from the control unit bracket -4-.

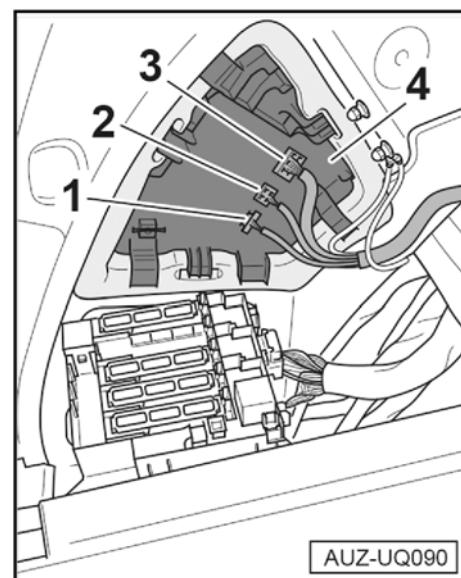



– Connect electrical connectors -2- and -3- of the onboard supply retrofit wiring harness to the trailer detector control unit -J345- -1-

#### Continue for all vehicles

- Connect electrical connector -5- of the "socket" retrofit wiring harness to the trailer detector control unit -J345- -1-.
- Insert the trailer detector control unit -J345- -1- with connected connectors in the control unit bracket -4- and engage.

#### Note

The electrical connectors can only be attached when the trailer detector control unit -J345- -1- has been removed

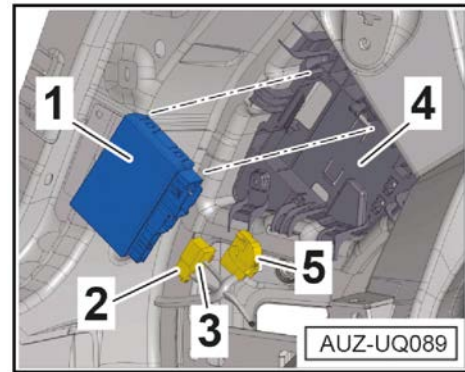

## 9.3 Routing the retrofit wiring harness

Only for vehicles without preparation "1D0".

1 - Fitting trailer detector control unit -J345-

2 - Earth stud

- Luggage compartment, left

3 - Routing of onboard supply retrofit wiring harness

4 - Wiring connection, convenience system central control unit -J393-

- CAN bus connection
- Brake light/terminal 15 connection

5 - Wiring connection, power supply to fuse carrier

- Fuse 5: 25 A
- Fuse 7: 15 A
- Fuse 8: 25 A
- Fuse 9: 15 A

6 - Routing of socket retrofit wiring harness

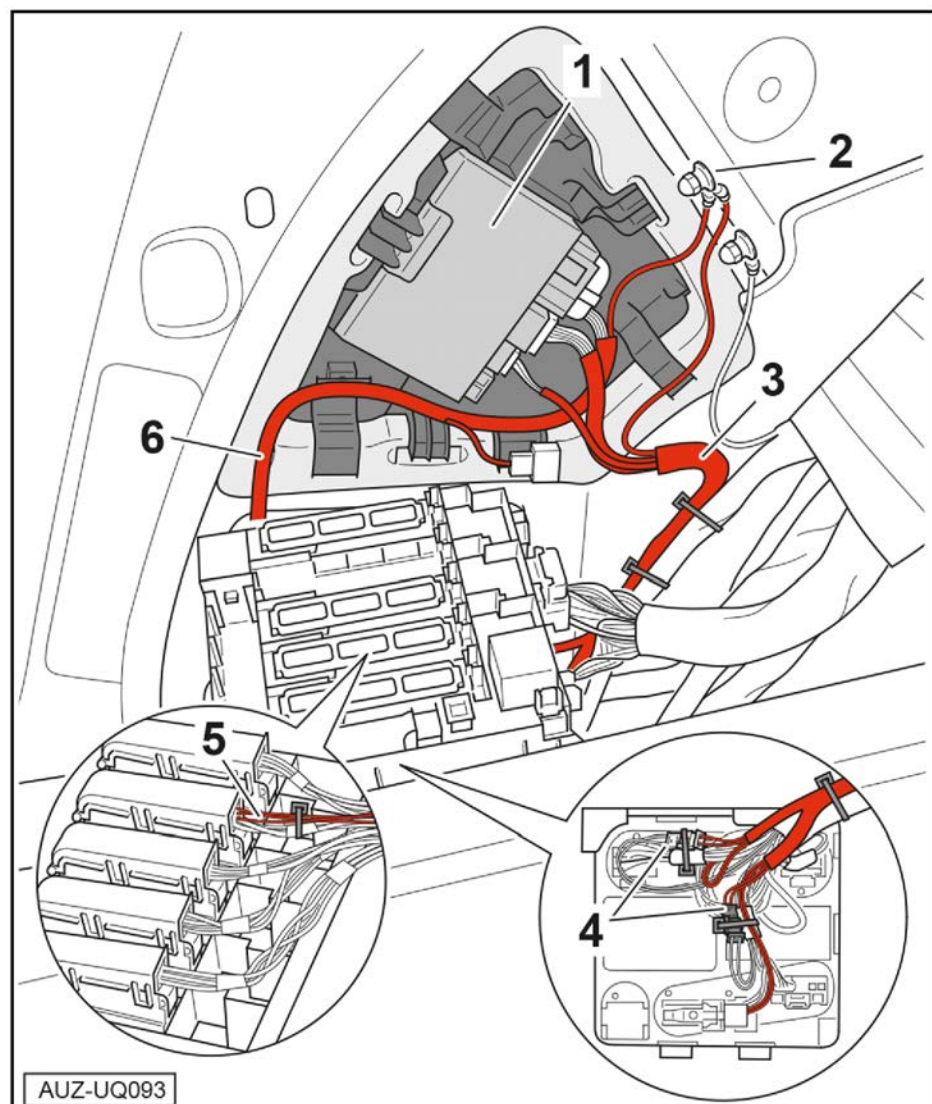



### Only applies to Q7 e-tron

The wiring connection for the power supply to the fuse carrier --5- is located above the rear left-hand wheel housing in the Q7 e-tron.

#### Note

- ◆ *In the Q7 e-tron, the fuse carrier -SF 3- -5- has a different position and design, but its functionality is identical.*
- ◆ *The other components -1-6- are the same and can be seen in the figure.*

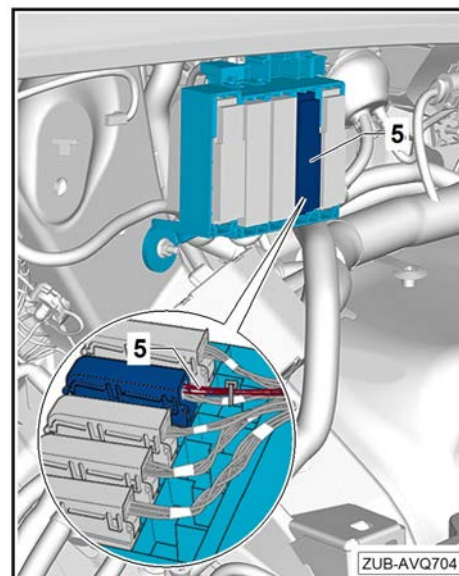



Only on vehicles with PR number "1D8" (preparation for towing bracket)

- 1 - Fitting trailer detector control unit -J345-
- 2 - Earth stud
  - Luggage compartment, left
- 3 - Onboard supply wiring harness
  - On the vehicle
- 4 - Routing of socket retrofit wiring harness

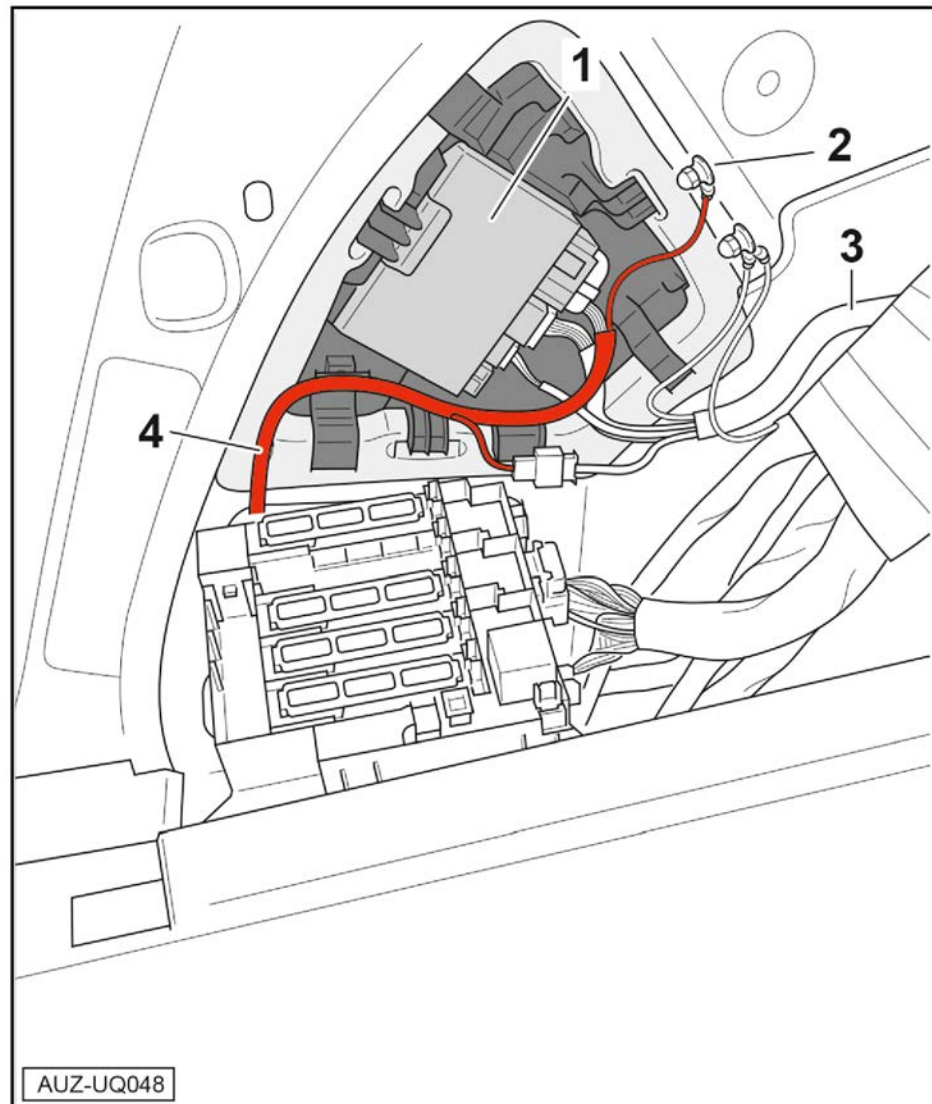

### 9.3.1 "Socket/swing motor" retrofit wiring harness routing

#### Next steps for all vehicles

- Fix the "socket" retrofit wiring harness -4- in position using retaining clips -arrows-.
- Clip the electrical connector -3- for the brake booster onto the trailer detector control unit -J345-.
- Establish the earth connection for the "socket" retrofit wiring harness on earth stud -2-.

#### Note

The nut on earth stud -2- is only screwed in once the onboard supply retrofit wiring harness has been routed.

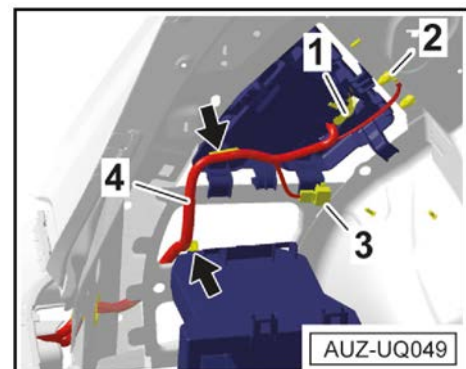



### 9.3.2 Routing of onboard supply retrofit wiring harness

Only for vehicles without preparation "1D0".

- Route the onboard supply retrofit wiring harness -3- along the vehicle's wiring harness and secure to the vehicle's wiring harness using cable ties -arrows-.

The wires must be secured with cable ties in a manner that prevents slipping or abrasion.

- Establish the earth connection for the onboard supply retrofit wiring harness on earth stud -2-.

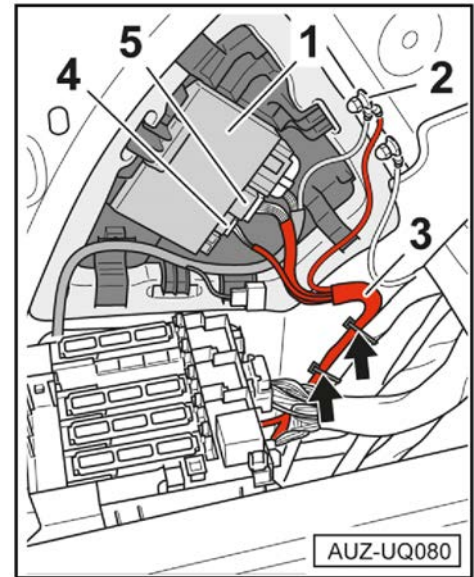

### 9.3.3 Routing the onboard supply retrofit wiring harness for Q7 e-tron

The onboard supply retrofit wiring harness is only installed on vehicles without preparation for towing brackets.

- Connect electrical connectors -5 and 6- of the onboard supply retrofit wiring harness -3- to the trailer detector control unit -J345- -1-.
- Route the onboard supply retrofit wiring harness -3- along the vehicle wiring harness and secure to the vehicle wiring harness using cable ties.

The wires must be secured with cable ties in a manner that prevents slipping or abrasion.

- Establish the earth connection for the onboard supply retrofit wiring harness on earth stud -2-.

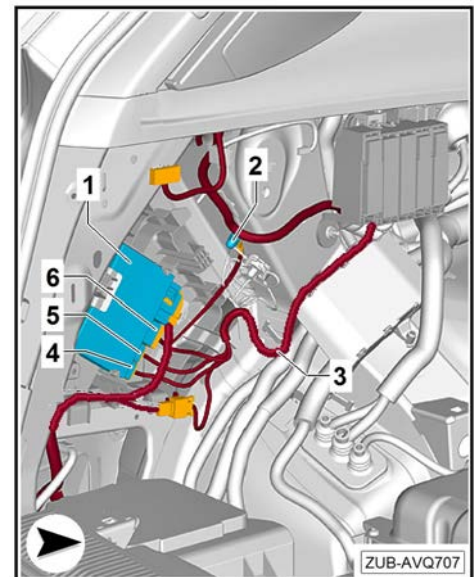

#### Next steps for all vehicles

- Tighten the nut on earth stud -2- for the earth connection of the "onboard supply" retrofit wiring harness using tightening torque .

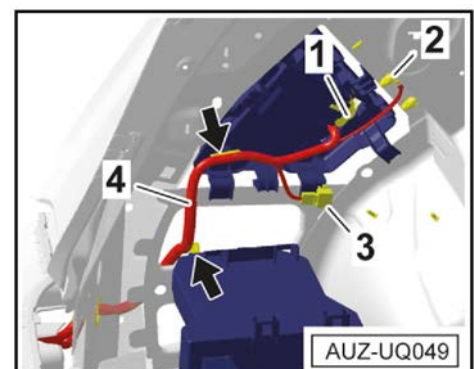



- Connect the electrical connector -1- of the "onboard supply" wiring harness to the corresponding connector of the "socket" retrofit wiring harness -arrow-.

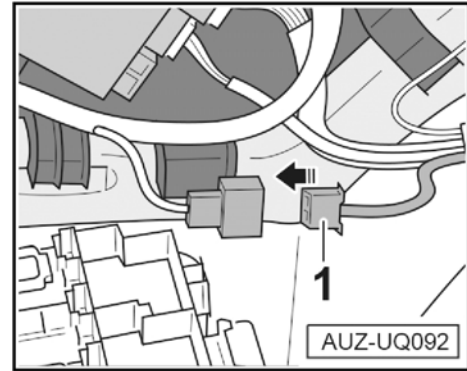

## 9.4 Connecting the onboard supply retrofit wiring harness

Only for vehicles without preparation "1D0".

### 9.4.1 Integrating the CAN bus

- Release the blue connector -3- from the convenience system central control unit -J393- and disconnect.

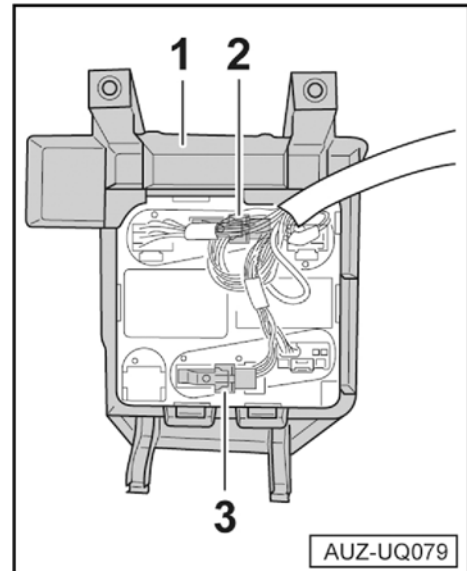

- Release the catches on the blue connector housing -arrows- and pull the connector block out of the connector housing.

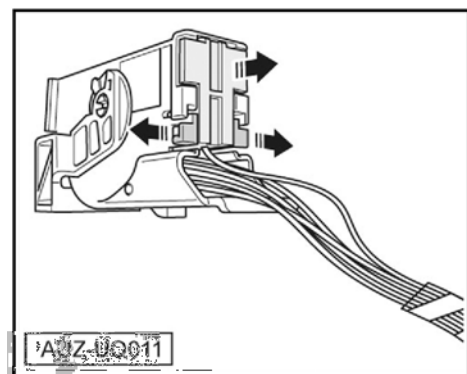





- Unpin contact from compartment -1- of the connector block.
- Unpin contact from compartment -2- of the connector block.

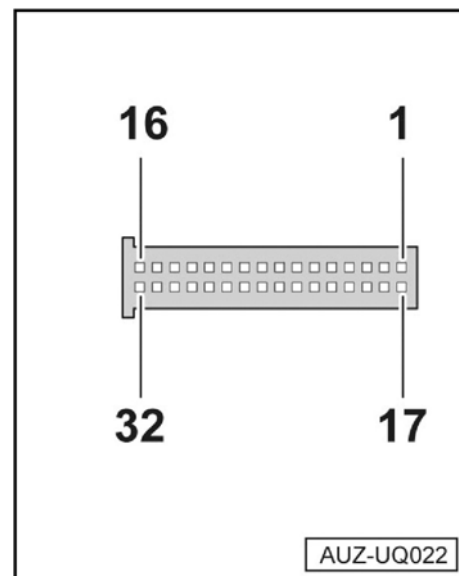

- Pin contact 1 of the connector block into compartment -1- of the included black socket housing -A- (3 chambers).
- Pin contact 2 of the connector block into compartment -3- of the included black socket housing -A- (3 chambers).

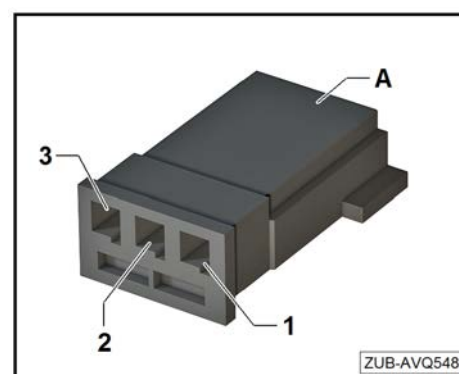

- Pin the corresponding contacts of the onboard supply retrofit wiring harness (Y-wires) into the compartments on the connector block.
- Pin the -orange/brown- wire of the retrofit wiring harness into compartment -1- of the connector block (CAN bus Low).
- Pin the -orange/green- wire of the retrofit wiring harness into compartment -2- of the connector block (CAN bus High).
- Insert the connector block into the blue connector housing and click into place.

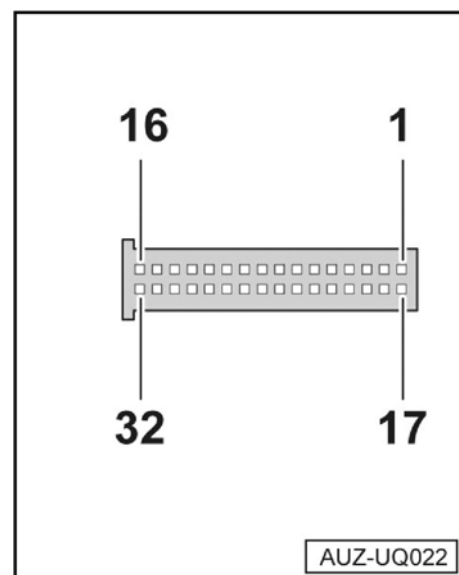



- Connect the socket housing (black) with the corresponding black connector on the onboard supply retrofit wiring harness -arrow-.
- Connect the blue connector to the convenience system central control unit -J393- and lock.

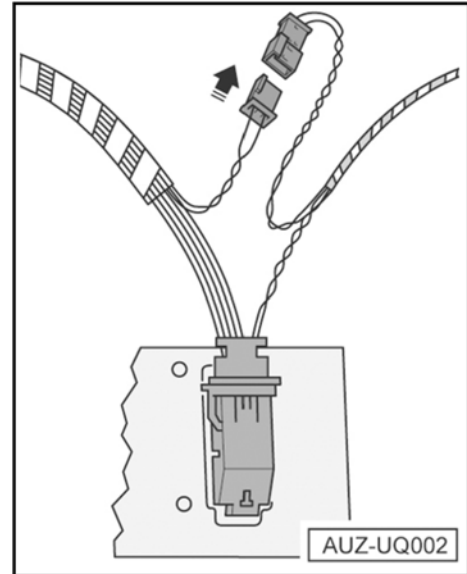

#### 9.4.2 Connecting the brake light signal/terminal 15

- Release and disconnect the black, 32-pin connector -2- from the convenience system central control unit -J393-.

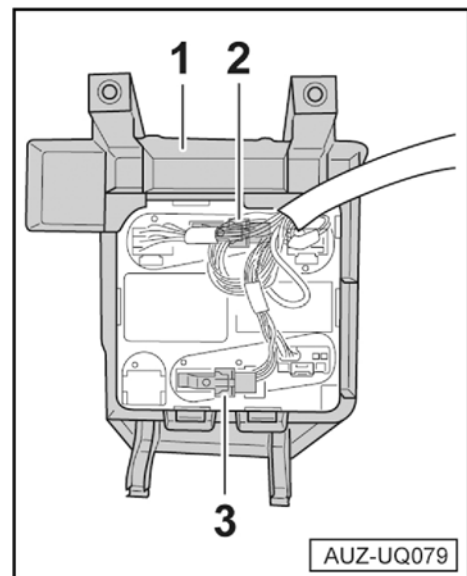

- Release the catches on the black connector housing -arrows- and pull the connector block out of the connector housing.

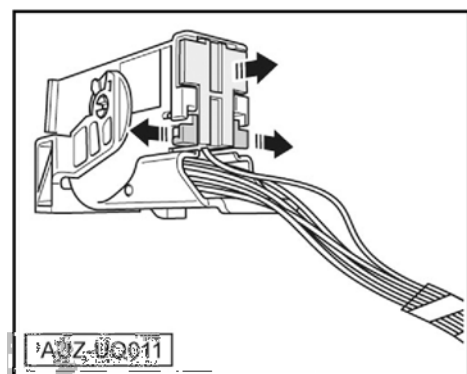



- Unpin contact from compartment -12- of the connector block.
- Unpin contact from compartment -17- of the connector block.

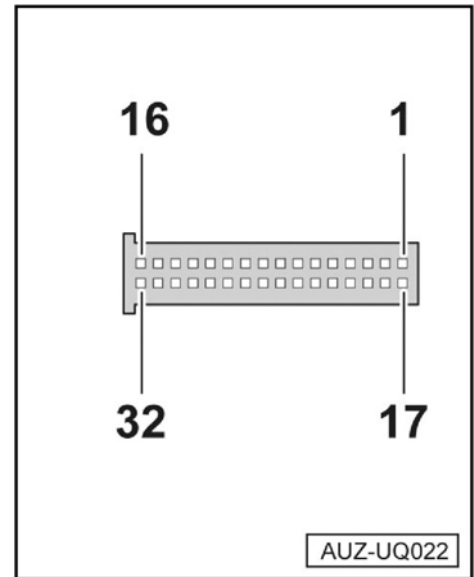

- Pin contact 12 of the connector block into compartment -3- of the included white socket housing -A- (3 chambers).
- Pin contact 17 of the connector block into compartment -1- of the included white socket housing -A- (3 chambers).

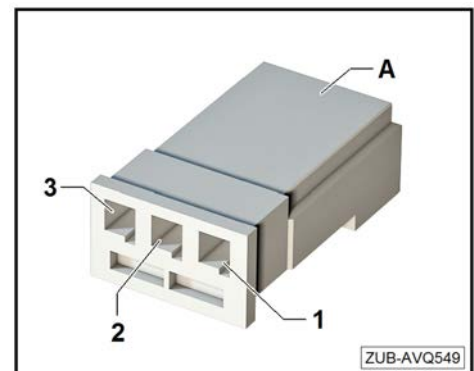

- Pin the corresponding contacts of the onboard supply retrofit wiring harness (Y-wires) into the compartments on the connector block.
- Pin the -black/red- wire from the -12- retrofit wiring harness into compartment of the connector block.
- Pin the -black- wire from the -17- retrofit wiring harness into compartment of the connector block.
- Insert the connector block into the black connector housing and click into place.

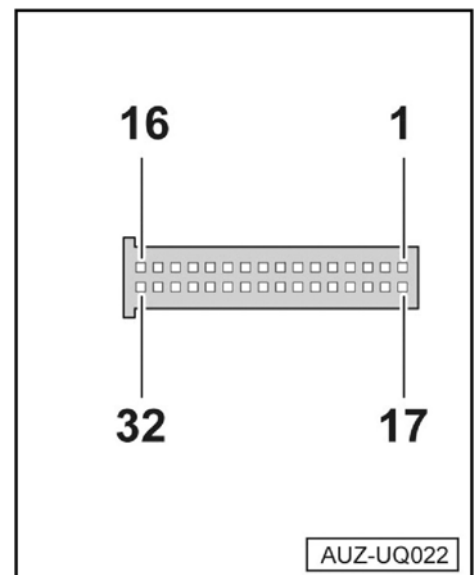



- Connect the socket housing (white) with the corresponding white connector on the onboard supply retrofit wiring harness -arrow-.
- Connect the black connector to the convenience system central control unit -J393- and lock.

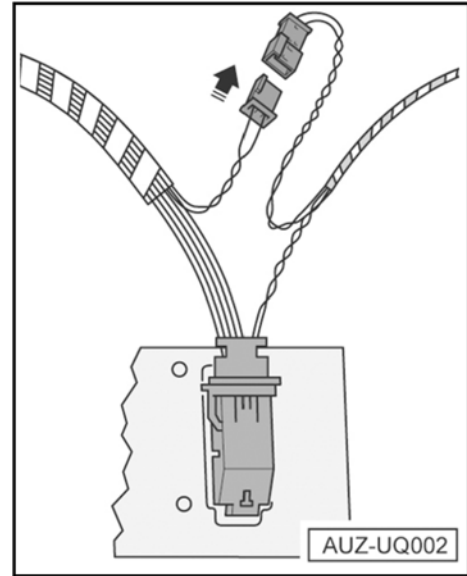

- Secure the onboard supply retrofit wiring harness to the vehicle's wiring harness using cable ties -arrows-.
- The wires must be secured with cable ties in a manner that prevents slipping or abrasion.

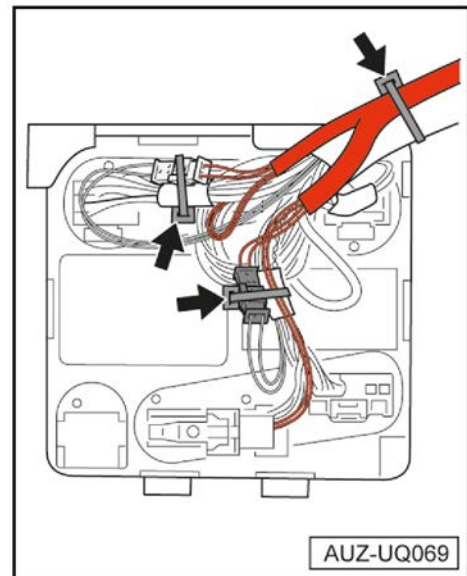

## 9.5 Installing the holder and convenience system central control unit -J393-

- Insert holder -1- along with the convenience system central control unit -J393- into the guides -2-.

### Note

Route electrical wiring in such a way that the original wiring routing is restored.

- Position and tighten securing nuts -3-.
- Tightening torque for securing nuts -3- 3 Nm.

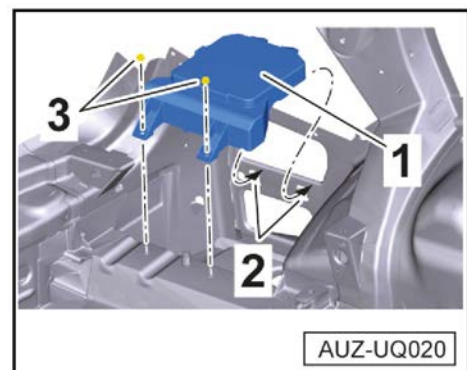



## 9.6 Establishing a power supply

### Only for vehicles without preparation "1D0".

- Release the retaining tab -arrow- and remove the fuse carrier from position -2- of the relay and fuse holder F -1- in a downwards direction.

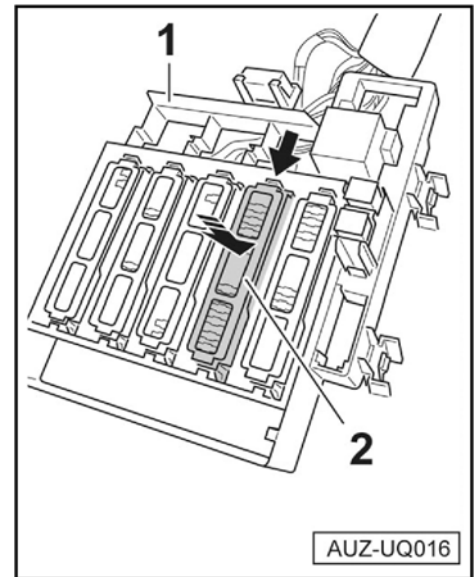

- Release the retaining clips -in the direction of the arrow- and remove the cover from the fuse carrier.

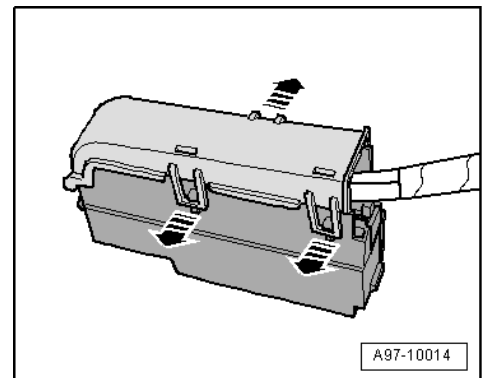

- Pull out the retaining strip -1- for the electrical connectors -in the direction of the arrow-.

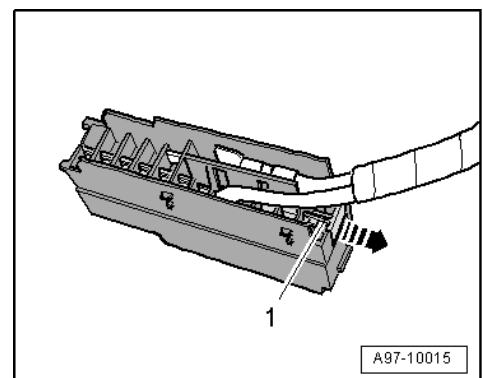



- Unlock the retainer from the fuse carrier -arrows- and remove -in the direction of the arrow-.

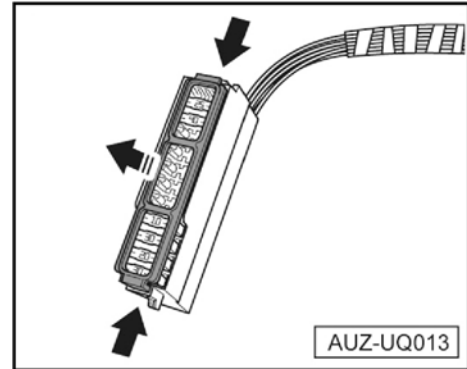

- Plug the onboard supply retrofit wiring harness contacts into fuse positions -5 to 9- on the fuse carrier.

- ◆ Compartment 9a: red wire
- ◆ Compartment 8a: red/blue wire
- ◆ Compartment 7a: red/green wire
- ◆ Compartment 5a: red/black wire

**⚠ WARNING**

**Compartment 6a must be kept empty – risk of errors in the vehicle electronics!**

- Insert the electrical connector retaining strip.
- Connect fuses 5, 7, 8 and 9.
- ◆ Fuse 9: 15 A
- ◆ Fuse 8: 25 A
- ◆ Fuse 7: 15 A
- ◆ Fuse 5: 25 A
- Install the retainer on the fuse carrier and lock.
- Install the cover for the fuse carrier and lock.
- Insert the fuse carrier into position -2- of the relay and fuse carrier F -1- and click into place.

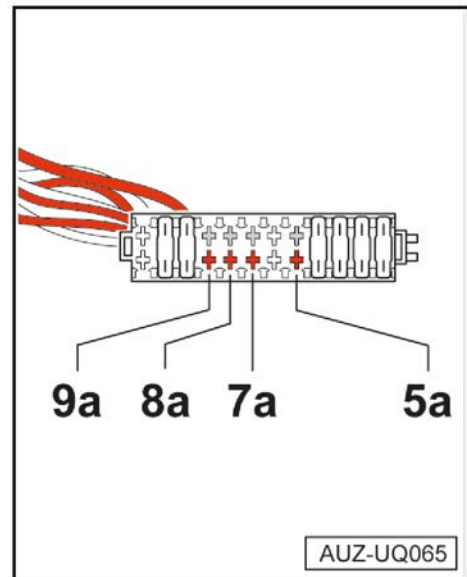

**i Note**

*Route electrical wiring in such a way that the original wiring routing is restored.*

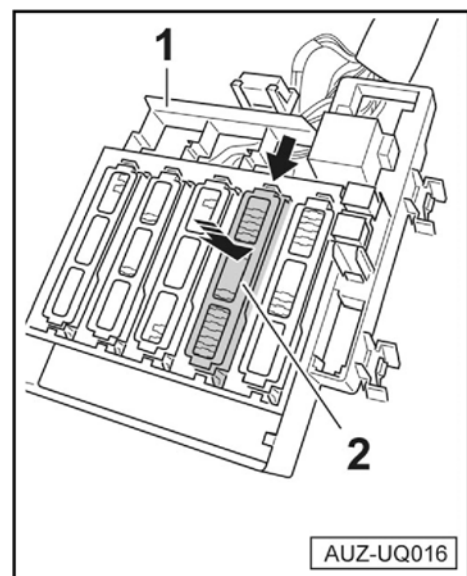



- Secure the onboard supply retrofit wiring harness to the vehicle's wiring harness using cable ties -arrow-.
- The wires must be secured with cable ties in a manner that prevents slipping or abrasion.
- Install the relay and fuse holder -F-

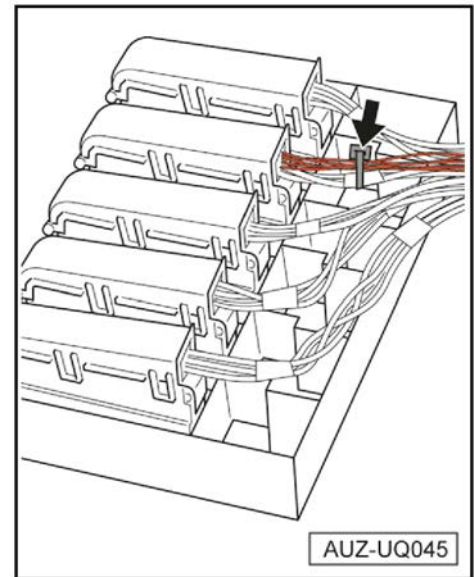

## 9.7 Connecting the fuses for the power supply

Only for vehicles with preparation "1D8".

- Release and remove the fuse carrier lock.
- Connect fuses 5, 7, 8 and 9.
- ◆ Fuse 9: 15 A
- ◆ Fuse 8: 25 A
- ◆ Fuse 7: 15 A
- ◆ Fuse 5: 25 A

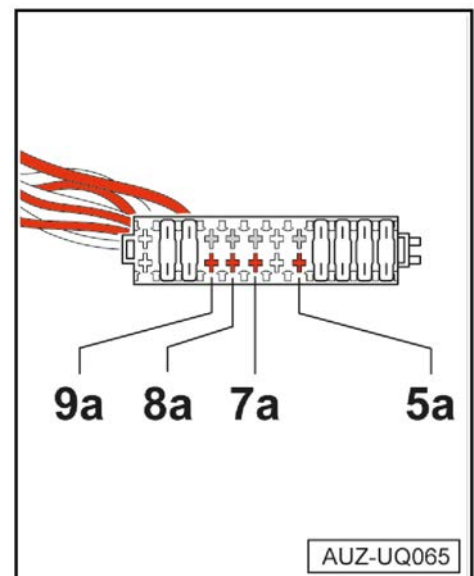



- Install the retainer on the fuse carrier and lock.
- Install the cover for the fuse carrier and lock.
- Insert the fuse carrier into position -2- of the relay and fuse carrier F -1- and click into place.

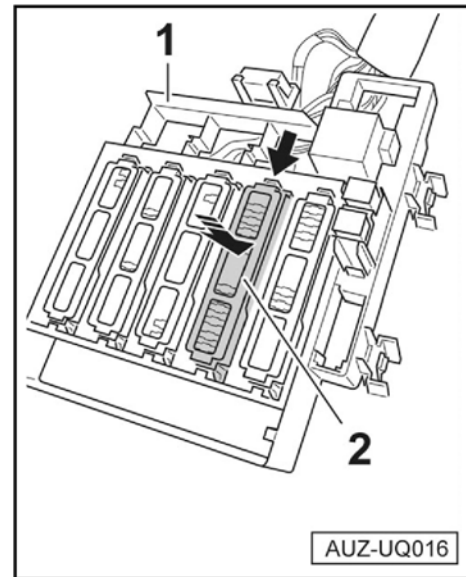

## 9.8 Connecting the battery

- Workshop Manual ⇒ Electrical system; Rep. gr. 27; Disconnecting and connecting the battery

### Note

*After reconnecting the power supply, the ESP warning light can only extinguish after a few metres have been driven.*

## 9.9 Adapting the trailer detector control unit -J345- coding

- ◆ It must be guaranteed that the open-circuit voltage of the vehicle battery is at least 12.5 Volts. To maintain the vehicle voltage during the process, connect a battery charger -VAS 590X-.
- ◆ If the procedure and test operation is completed without errors, the vehicle configuration is only performed once. Unless prompted, multiple attempts to configure the vehicle can cause error messages and have no impact on the configuration.
- ◆ The FM code (activation code), the license number (activation number) and the PIN (activation PIN) are required to update the software. This information can be found in the enclosed software certificate.
- Connect the vehicle diagnostic tester with ODIS service to the diagnostic connection on the vehicle when the ignition is switched off.
- Switch on ignition.
- Select the "Start diagnosis" (Diagnose starten) operating mode and identify the vehicle.





- Switch to the "Control units" (Steuergeräte) tab and call up the "Event memory list" (Ereignisspeicherliste) to obtain an overview of all stored entries in the event memory.
- Rectify any relevant faults and clear the event memory.
- Switch to the "Special functions" (Sonderfunktionen) tab and select "Software Version Management (SVM)".
- Start "SVM - Enable" (SVM - Freischaltung) and observe notes and test conditions!
- Select "-1- Enable newly acquired data/functions" (-1- neu erworbene Daten/Funktionen freischalten) and follow the instructions given by the vehicle diagnostic tester.

After the code is entered, the online connection is established and the software adaptation is carried out.

- End diagnosis.
- Switch off the ignition and disconnect the vehicle diagnostic tester.

## 9.10 Functional check on the socket

- Check that the trailer socket functions correctly using a suitable trailer socket tester or a trailer.

### Pin assignment at the trailer socket

- 1 - Terminal LH (left-hand brake light/turn signal)
- 2 - Terminal 31 (earth)
- 3 - Electrical brake (brake booster)
- 4 - Terminal RH (right-hand brake light/turn signal)
- 5 - Terminal 30 (battery +)

#### **Note**

*Constant current 12 V, max. current 15 A.*

- 6 - Terminal 58 (tail lights)
- 7 - Terminal RVL (reversing light)

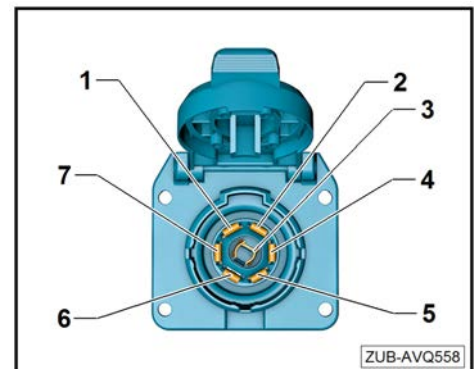



## 10 Concluding operations

### 10.1 Creating the opening required for the ball coupling

Applies to Q7 2015 ►, Q7 e-tron 2016 ► (before product upgrade)

#### Note

- ◆ Depending on the equipment variant, the bracket with a wide cut-out for the towing bracket must be replaced with a new bracket with a narrow cut-out.
- ◆ Depending on the bumper variant, a cut-out must be created.

#### Diffuser adjustment without opening for towing bracket with bracket for rear lid power opening control unit -J938-

A - Mark the position of the bracket -2- on the diffuser -1- on the left-hand and right-hand side using a white pen -magnifying glass-.

B - Loosen the bracket -2- from the diffuser -1- with a plastic wedge -3- -direction of arrow-.

- Position and align the new bracket -2- on the positions -3- and -4- of the diffuser -1-.
- With a white pen, copy the outline -5- of the bracket -2- onto the diffuser -1-.

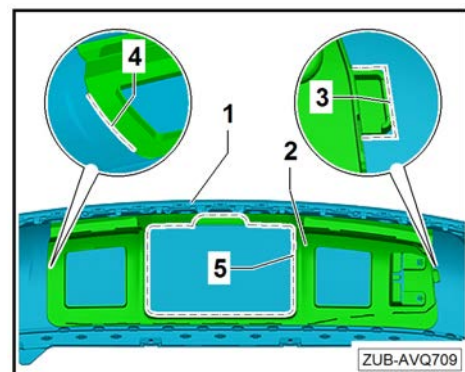
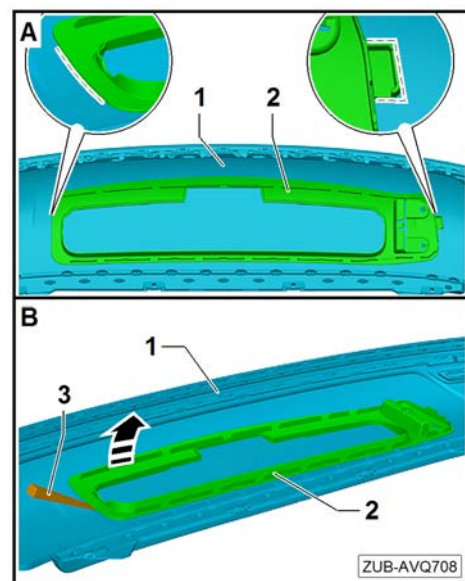



- Remove the bracket and mark out the outline of the entire circumference of the -white line- 2 mm from the line -red line-.
- Cut out the diffuser along the -red line- and deburr the cut edges.
- Place the bracket on the diffuser and check that the opening is a perfect match; if necessary, rework the opening!
- ◆ The diffuser and bracket must be at room temperature.
- The bonding surfaces of the diffuser must be completely dry, clean and free of wax and grease.
- Remove the protective film from the adhesive tape -6- all over the bracket -2-.
- Insert the bracket -2- into the opening on the diffuser -1- and press down on marks -3 and 4-.
- ◆ Leave the vehicle at room temperature for a minimum of 1 hour.
- ◆ Load-bearing after at least 24 hours.

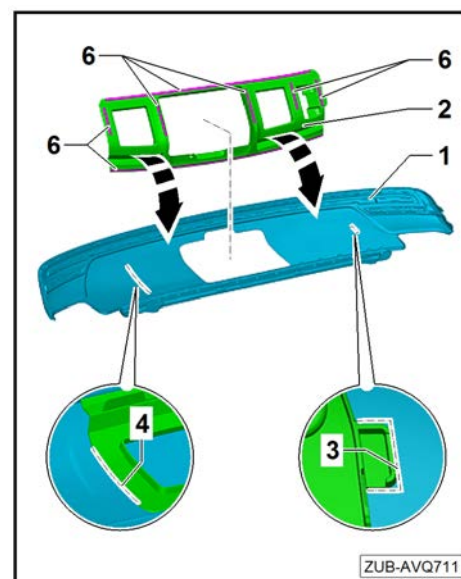
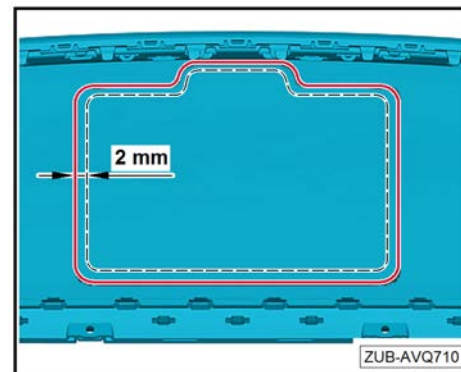

## 10.2 Creating the opening required for the ball coupling

Applies only to Q7 2015.

**Diffuser adjustment without bracket for rear lid power opening control unit -J938- and without opening for towing bracket.**

- Measure dimension A = 320 mm Measure the rear bumper cover diffuser starting from the centre point -3- and mark the lines -2-.
- Measure dimension B = 220 mm Measure the rear bumper cover diffuser starting from the edge -1- and mark the lines -4-.
- Cut out the diffuser along the edge -1- and the marked lines -2- and -4- using a suitable tool.
- Carefully deburr the cut edges.

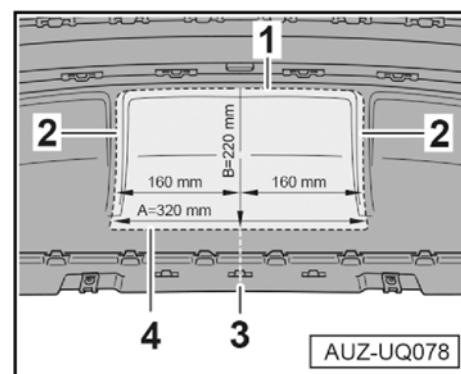

### Genuine part diffuser with towing bracket opening

Rear bumper cover diffuser with towing bracket ⇒ Electronic parts catalogue "ETKA"

EN



### 10.3 Diffuser adjustment with the bracket for rear lid power opening control unit -J938- when a score line is available.

Applies to Q7 (PU) 2020 ►

#### Note

- ◆ Depending on the equipment variant, the bracket with a wide cut-out for the towing bracket must be replaced with a new bracket with an additional cut-out.
- ◆ Check whether a score line is available (depends on the bumper variant). If a score line is available, use it to create the cut-out independently.
- ◆ If there is no score line, use the template provided in the appendix to create the cut-out ⇒ [Page 41](#).

#### Diffuser adjustment when a score line is available.

A - Position of the bracket -2- on the diffuser -1- on the left-hand and right-hand side -magnifying glass-.

B - Loosen the bracket -2- from the diffuser -1- with a plastic wedge -3- -direction of arrow-.

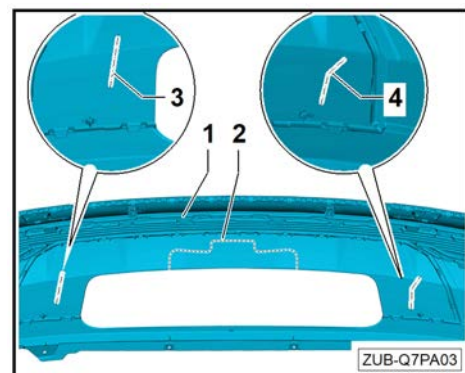
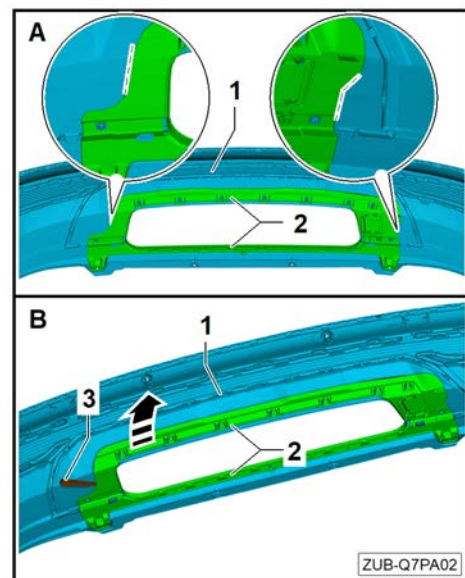

- Cut out the diffuser along the -score line 2- and deburr the cut edges.
- Note the specified position lugs -3 and 4-.
- Place the bracket on the diffuser and check that the opening is a perfect match; if necessary, rework the opening!
- ◆ The diffuser and bracket must be at room temperature.
- The bonding surfaces of the diffuser must be completely dry, clean and free of wax and grease.



- Remove the protective film from the adhesive tape -6- all over the bracket -2-.
- Insert the bracket -2- into the opening on the diffuser -1- and press down on marks -3 and 4-.
- ◆ Leave the vehicle at room temperature for a minimum of 1 hour.
- ◆ Load-bearing after at least 24 hours.

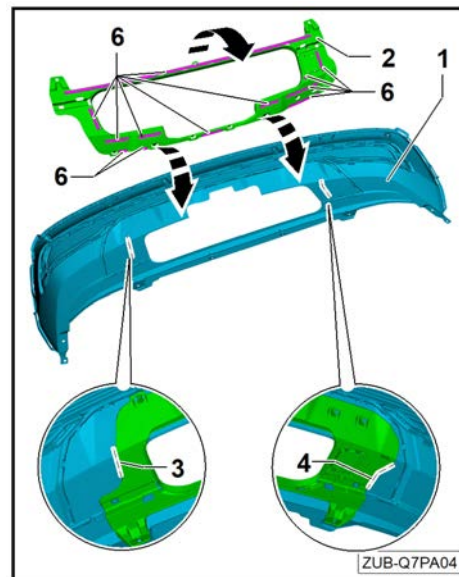

## 10.4 Diffuser adjustment with bracket for rear lid power opening control unit -J938- without a score line.

Applies to Q7 (PU) 2020 ►

### Note

- ◆ Depending on the equipment variant, the bracket with a wide cut-out for the towing bracket must be replaced with a new bracket with an additional cut-out.
- ◆ Check whether a score line is available (depends on the bumper variant). If a score line is available, use it to create the cut-out independently.
- ◆ If no score line is available, use the template provided in the appendix to create the cut-out.

### Diffuser adjustment without a score line.

A - Position of the bracket -2- on the diffuser -1- on the left-hand and right-hand side -magnifying glass-.

B - Loosen the bracket -2- from the diffuser -1- with a plastic wedge -3- -direction of arrow-.

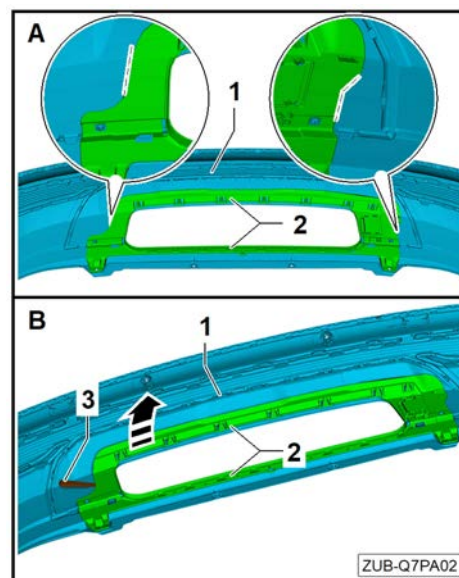



**⚠ WARNING**

**The appendix to the installation instructions contains a template for creating the additional opening in the diffuser.**

**Print out the template.**

**The template features a positioning mark. Using a ruler, measure the positioning mark. This must be 10 cm.**

**If the dimension is too small or large, the printer options must be changed from "Fit" to "Actual size".**

- Cut out the template and stick it together using adhesive tape.
- Mark the centre -3- of the diffuser cut-out and position the template on the diffuser. Secure the template on the right-hand and left-hand side using adhesive tape.
- Mark the outline of the -template- on the diffuser, cut along the lines and deburr the cut edges.
- Place the bracket on the diffuser and check that the opening is a perfect match; if necessary, rework the opening!
- ◆ The diffuser and bracket must be at room temperature.
- The bonding surfaces of the diffuser must be completely dry, clean and free of wax and grease.
- Remove the protective film from the adhesive tape -6- all over the bracket -2-.
- Insert the bracket -2- into the opening on the diffuser -1- and press down on position lugs -3 and 4-.
- ◆ Leave the vehicle at room temperature for a minimum of 1 hour.
- ◆ Load-bearing after at least 24 hours.

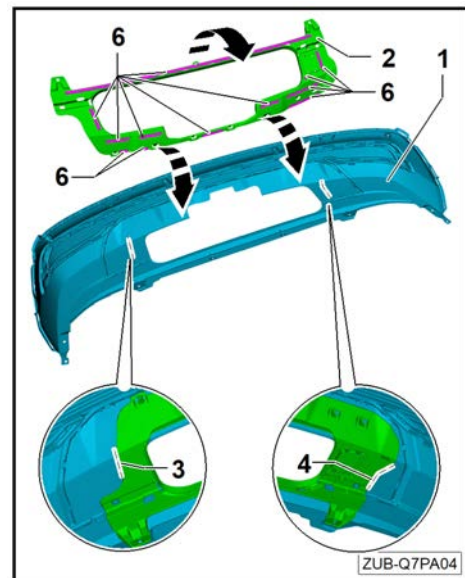
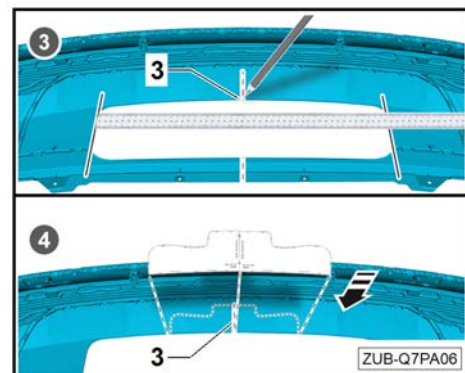
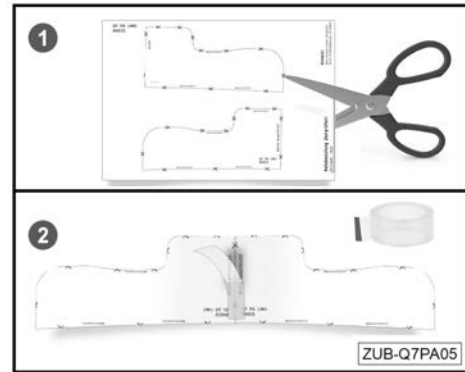

## 10.5 Reassembling the vehicle

The vehicle is assembled in the reverse order. Read and observe the notes on installation for the relevant components and the corresponding tightening torques.

On vehicles with lane change assist, this must be recalibrated.



**⚠ WARNING**

**The following information must be observed when working with the lane change assist (Audi side assist):**

- ◆ **If the rear bumper cover is removed and then reinstalled, or if any modifications are made to the rear bumper cover, the lane change assist system (Audi side assist) must be recalibrated ⇒Electrical system; Rep. gr. 96; Risk of accident due to malfunction!**

**With regard to vehicles fitted with a rear view camera, observe the following:**

- ◆ **If the rear bumper cover is removed and then reinstalled, or if any modifications are made to the rear bumper cover, the rear view camera system must be calibrated ⇒Electrical system; Rep. gr. 91; Calibrate the rear view camera system!**

## 10.6 Finishing the assembly work

- Attach the enclosed sticker with the warning message "Electric brake for trailer not connected" to a clean surface in an easily visible position near the decal (ball position) or on the dash panel.

**i Note**

**Bonding surfaces must be dry and free of dust and grease!**

- Once assembled, check the towing bracket functions correctly ⇒ Owner's Manual.
- Keep these assembly instructions with the vehicle documents so that they can be presented to authorised persons upon request.

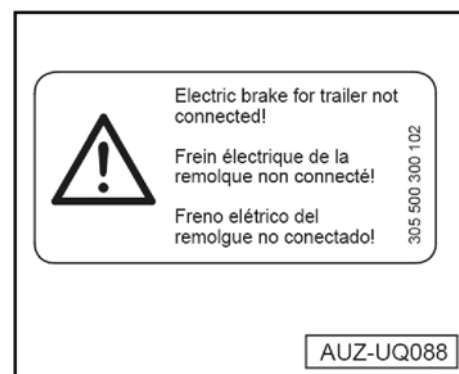

## 10.7 Adjusting the cooling system

As trailer operation puts greater demands on the engine cooling system, the cooling system is upgraded, where technically possible, when the towing bracket is installed in the factory. This is achieved by installing a more powerful or second cooling fan and/or a larger cooler. Hot country versions of vehicles and/or those with air conditioning systems have a more powerful engine cooling system, but this system may not be sufficient for towing.

When a towing bracket is retrofitted, the cooling unit should be upgraded unless this has already been done at the factory. Otherwise, a high engine load (e.g. mountains, high ambient temperatures, high trailer load) could cause the cooling system to overheat. In the event of an alteration, the parts in the Genuine Parts catalogue must be used in the engine cooling system during trailer operation. The work instructions in the relevant workshop manuals must also be observed.



The cooling system does not need to be upgraded if it is possible to guarantee that the engine is only exposed to moderate stress, e.g.:

- ◆ The permissible gross combination weight is significantly underrun
- ◆ No high ambient temperatures
- ◆ No long, steep inclines
- ◆ No high altitude journeys

In any case, the coolant temperature display must be carefully monitored. If the needle in the display moves into the hot area, the speed must be reduced immediately. A cool-down time must also be allowed for if necessary. This involves the allowing the engine to idle for approx. 2 minutes to prevent a build-up of heat.

 **Note**

- ◆ *In vehicles with air-conditioning, the engine cooling system can be relieved by switching off the air-conditioning. This also improves the vehicle's start-up behaviour and makes it safer to overtake.*
- ◆ *If, in exceptional cases, the cooling system does not need to be upgraded, the seller must advise the buyer accordingly if the vehicle is sold.*









